

Features

- Low on resistance $R_{DS(ON)}$
- Low gate threshold voltage
- Low input capacitance
- ESD protected up to 2KV

MARKING

- MARKING: 72K

Package

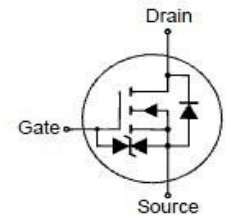
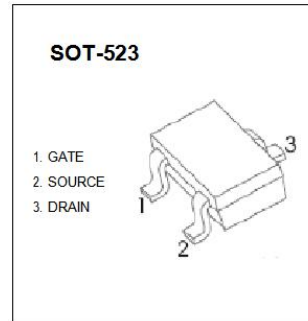

Absolute Maximum Ratings ($T_a = 25^\circ\text{C}$)

| Parameter | Symbol | Value | Unit |
|--|----------------|---------------|------------------|
| Drain-Source Voltage | V_{DSS} | 60 | V |
| Gate-Source Voltage | V_{GSS} | ± 20 | V |
| Drain Current (Continuous) | I_D | 300 | mA |
| Drain Current (Pulse Width $\leq 10 \mu\text{s}$) | I_{DM} | 800 | mA |
| Total Power Dissipation | P_{tot} | 350 | mW |
| Operating and Storage Temperature Range | T_j, T_{stg} | - 55 to + 150 | $^\circ\text{C}$ |

Characteristics at $T_a = 25^\circ\text{C}$

| Parameter | Symbol | Min. | Max. | Unit |
|--|--------------|--------|----------|---------------|
| Drain Source Breakdown Voltage at $I_D = 10 \mu\text{A}$ | BV_{DSS} | 60 | - | V |
| Zero Gate Voltage Drain Current at $V_{DS} = 60 \text{ V}$ | I_{DSS} | - | 1 | μA |
| Gate Source Leakage Current at $V_{GS} = \pm 20 \text{ V}$ | I_{GSS} | - | ± 10 | μA |
| Gate Threshold Voltage at $V_{DS} = 10 \text{ V}, I_D = 250 \mu\text{A}$ | $V_{GS(th)}$ | 1 | 2.5 | V |
| Static Drain Source On-Resistance at $V_{GS} = 10 \text{ V}, I_D = 500 \text{ mA}$ at $V_{GS} = 4.5 \text{ V}, I_D = 200 \text{ mA}$ | $R_{DS(ON)}$ | - - | 3 4 | Ω |
| Diode Forward Voltage $I_S=115\text{mA}, V_{GS}=0 \text{ V}$ | V_{SD} | 0.55 | 1.2 | V |
| Forward Transconductance at $V_{DS} = 10 \text{ V}, I_D = 200 \text{ mA}$ | g_{fs} | 80 | - | mS |
| Input Capacitance at $V_{DS} = 25 \text{ V}, f = 1 \text{ MHz}$ | C_{iss} | - | 50 | pF |
| Output Capacitance at $V_{DS} = 25 \text{ V}, f = 1 \text{ MHz}$ | C_{oss} | - | 25 | pF |
| Reverse Transfer Capacitance at $V_{DS} = 25 \text{ V}, f = 1 \text{ MHz}$ | C_{rss} | - | 5 | pF |



Typical Characteristics

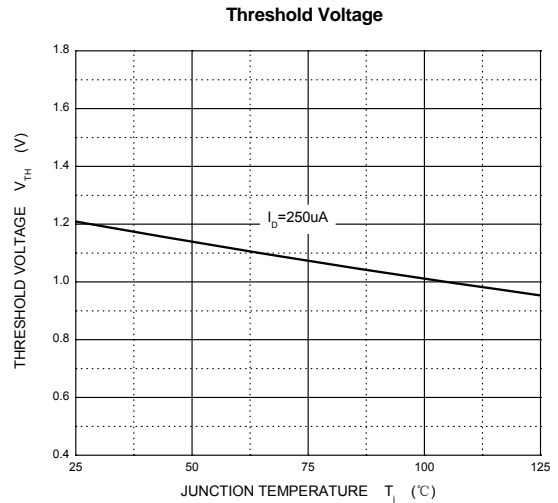
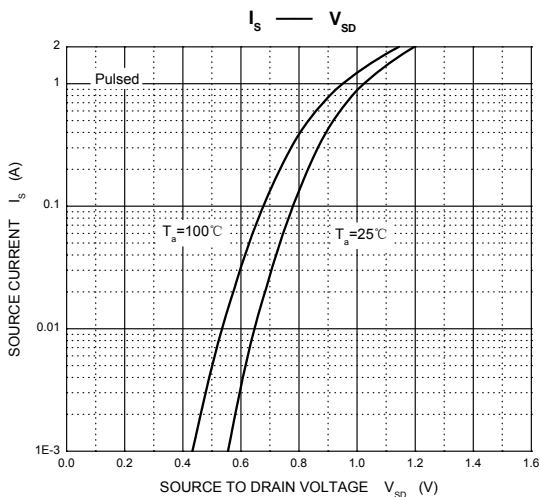
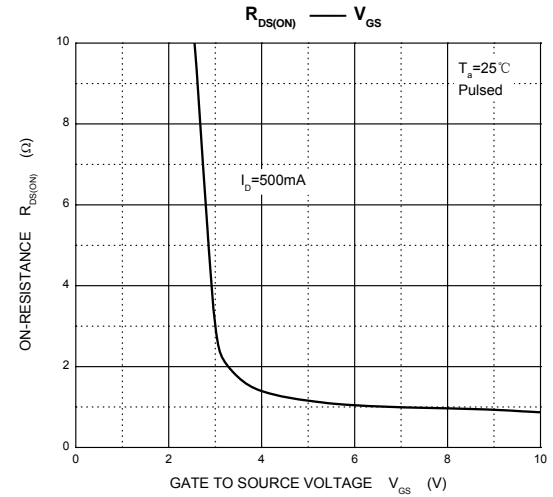
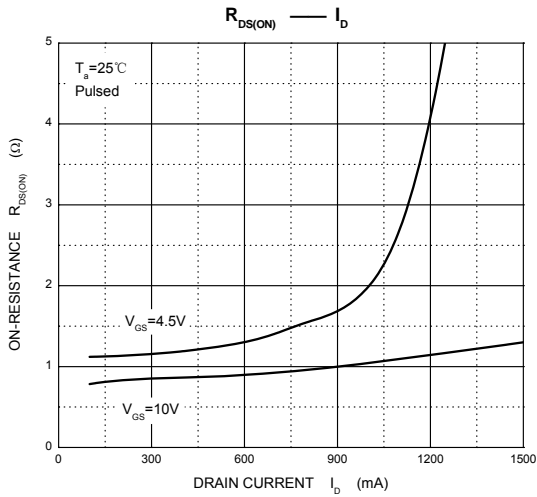
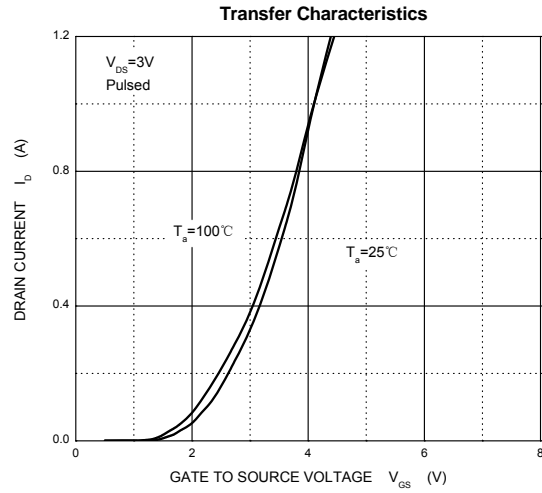
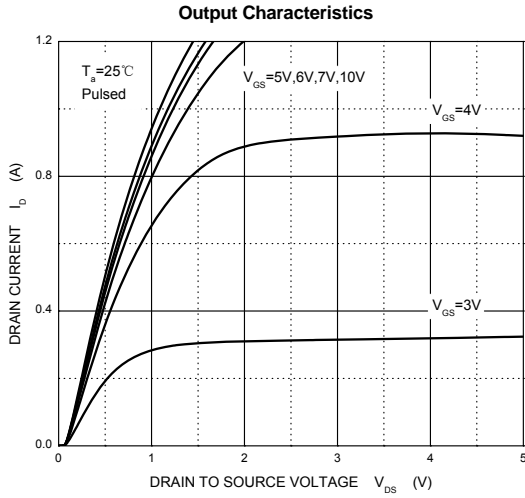

SOT-523 Package Outline Dimensions

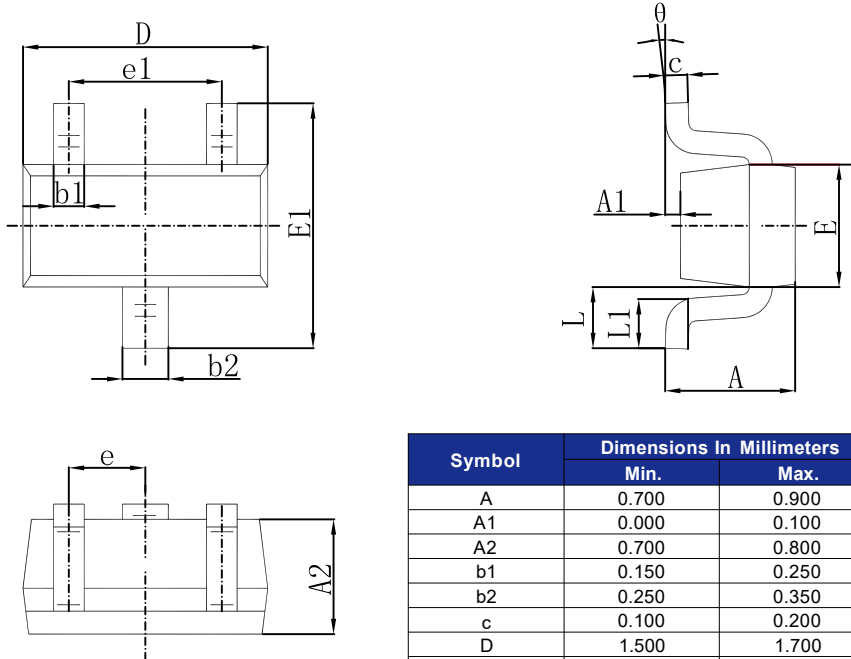

| Symbol | Dimensions In Millimeters | | Dimensions In Inches | |
|--------|---------------------------|-------|----------------------|-------|
| | Min. | Max. | Min. | Max. |
| A | 0.700 | 0.900 | 0.028 | 0.035 |
| A1 | 0.000 | 0.100 | 0.000 | 0.004 |
| A2 | 0.700 | 0.800 | 0.028 | 0.031 |
| b1 | 0.150 | 0.250 | 0.006 | 0.010 |
| b2 | 0.250 | 0.350 | 0.010 | 0.014 |
| c | 0.100 | 0.200 | 0.004 | 0.008 |
| D | 1.500 | 1.700 | 0.059 | 0.067 |
| E | 0.700 | 0.900 | 0.028 | 0.035 |
| E1 | 1.450 | 1.750 | 0.057 | 0.069 |
| e | 0.500 TYP. | | 0.020 TYP. | |
| e1 | 0.900 | 1.100 | 0.035 | 0.043 |
| L | 0.400 REF. | | 0.016 REF. | |
| L1 | 0.260 | 0.460 | 0.010 | 0.018 |
| theta | 0° | 8° | 0° | 8° |

SOT-523 Suggested Pad Layout

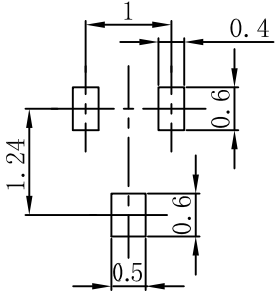

Note:
 1. Controlling dimension: in millimeters.
 2. General tolerance: ±0.05mm.
 3. The pad layout is for reference purposes only.