



Features

- Low $R_{DS(on)}$ @ $V_{GS}=10V$
- 5V Logic Level Control
- N Channel SOT-323 Package
- Pb-Free, RoHS Compliant

Applications

- LED Lighting Application,
- ON/OFF switch
- Networking

Order Information

| Type No. | Marking | Package Code |
|----------|---------|--------------|
| 2SK3018 | KN | SOT-323 |

| $V_{(BR)DSS}$ | $R_{DS(ON)}$ Typ | I_D Max |
|---------------|---------------------|-----------|
| 60V | 1.3 Ω @ 10V | 0.3A |
| | 1.6 Ω @ 4.5V | |

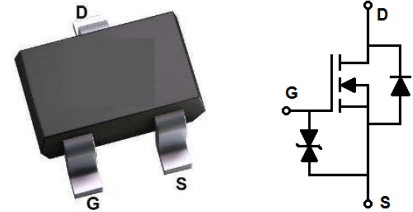

SOT323

Absolute Maximum Ratings

Stresses exceeding Maximum Ratings may damage the device. Maximum Ratings are stress ratings only. Functional operation above the Recommended Operating Conditions is not implied. Extended exposure to stresses above the Recommended Operating Conditions may affect device reliability.

| Symbol | Parameter | | Rating | Unit |
|--|-------------------------------------|----------------------|------------|------|
| Common Ratings (T _A =25°C Unless Otherwise Noted) | | | | |
| V _{GS} | Gate-Source Voltage | | ±20 | V |
| V _{(BR)DSS} | Drain-Source Breakdown Voltage | | 60 | V |
| T _J | Maximum Junction Temperature | | 150 | °C |
| T _{STG} | Storage Temperature Range | | -50 to 150 | °C |
| Mounted on Large Heat Sink | | | | |
| I _{DM} | Pulse Drain Current Tested① | T _A =25°C | 0.8 | A |
| I _D | Continuous Drain Current | T _A =25°C | 0.3 | A |
| | | T _A =70°C | 0.24 | |
| P _D | Maximum Power Dissipation | T _A =25°C | 0.3 | W |
| | | T _A =70°C | 0.2 | |
| R _{θJA} | Thermal Resistance Junction-Ambient | | 400 | °C/W |



| Symbol | Parameter | Condition | Min | Typ | Max | Unit |
|--|--|---|-----|------|-----|------|
| Static Electrical Characteristics @ T _J = 25°C (unless otherwise stated) | | | | | | |
| V _{(BR)DSS} | Drain-Source Breakdown Voltage | V _{GS} =0V I _D =250μA | 60 | -- | -- | V |
| I _{DSS} | Zero Gate Voltage Drain Current(T _A =25°C) | V _{DS} =60V, V _{GS} =0V | -- | -- | 1 | μA |
| | Zero Gate Voltage Drain Current(T _A =125°C) | V _{DS} =40V, V _{GS} =0V | -- | -- | 100 | uA |
| I _{GSS} | Gate-Body Leakage Current | V _{GS} =±20V, V _{DS} =0V | -- | -- | ±10 | uA |
| V _{GS(TH)} | Gate Threshold Voltage | V _{DS} =V _{GS} , I _D =250μA | 0.8 | 1.2 | 1.5 | V |
| R _{DS(ON)} | Drain-Source On-State Resistance② | V _{GS} =10V, I _D =0.3A | -- | 1.3 | 4 | Ω |
| R _{DS(ON)} | Drain-Source On-State Resistance② | V _{GS} =4.5V, I _D =0.2A | -- | 1.6 | 5 | Ω |
| R _{DS(ON)} | Drain-Source On-State Resistance② | V _{GS} =3.3V, I _D =0.1A | -- | 1.8 | 6 | Ω |
| Dynamic Electrical Characteristics @ T _J = 25°C (unless otherwise stated) | | | | | | |
| C _{iss} | Input Capacitance | V _{DS} =30V, V _{GS} =0V, f=1MHz | -- | 12 | -- | pF |
| C _{oss} | Output Capacitance | | -- | 3.2 | -- | pF |
| C _{rss} | Reverse Transfer Capacitance | | -- | 0.8 | -- | pF |
| Q _g | Total Gate Charge | V _{DS} =30V I _b =0.3A, V _{GS} =4.5V | -- | 0.58 | -- | nC |
| Q _{gs} | Gate Source Charge | | -- | 0.12 | -- | nC |
| Q _{gd} | Gate Drain Charge | | -- | 0.21 | -- | nC |
| Switching Characteristics | | | | | | |
| t _{d(on)} | Turn on Delay Time | V _{DD} =30V, I _b =0.3A, R _G =3.3Ω, V _{GS} =10V | -- | 4.5 | -- | ns |
| t _r | Turn on Rise Time | | -- | 3.1 | -- | ns |
| t _{d(off)} | Turn Off Delay Time | | - | 15 | -- | ns |
| t _f | Turn Off Fall Time | | -- | 3.3 | -- | ns |
| Source Drain Diode Characteristics | | | | | | |
| I _{SD} | Source drain current(Body Diode) | T _A =25°C | -- | -- | 0.2 | A |
| V _{SD} | Forward on voltage② | T _J =25°C, I _{sd} =0.2A, V _{GS} =0V | -- | 0.87 | 1.2 | V |

Notes:

① Pulse width limited by maximum allowable junction temperature

②Pulse test ; Pulse width≤300μs, duty cycle≤2%.

Typical Characteristics

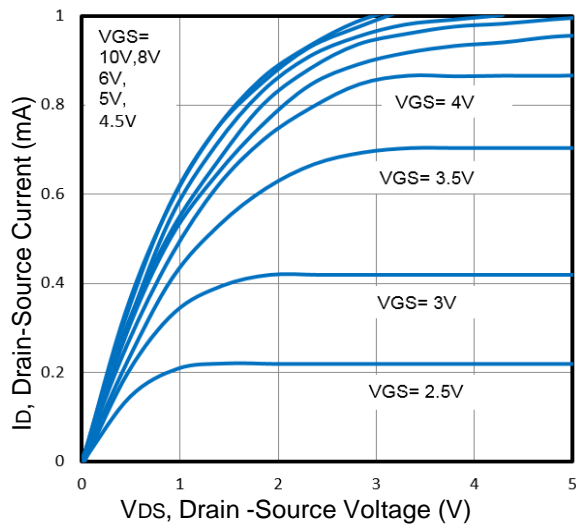

Fig1. Typical Output Characteristics

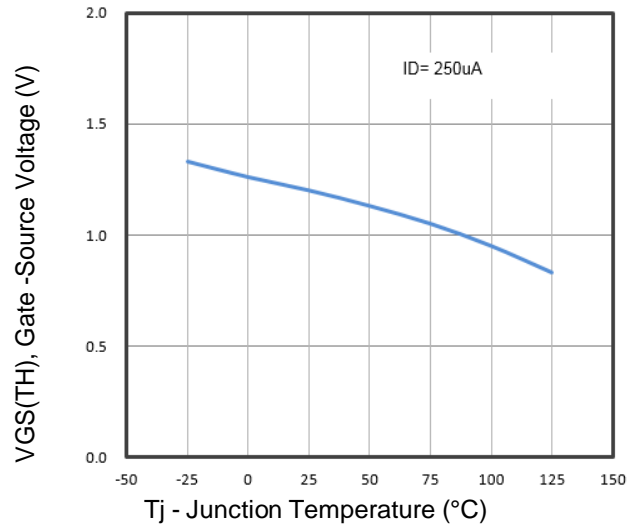

Fig2. Normalized Threshold Voltage Vs. Temperature

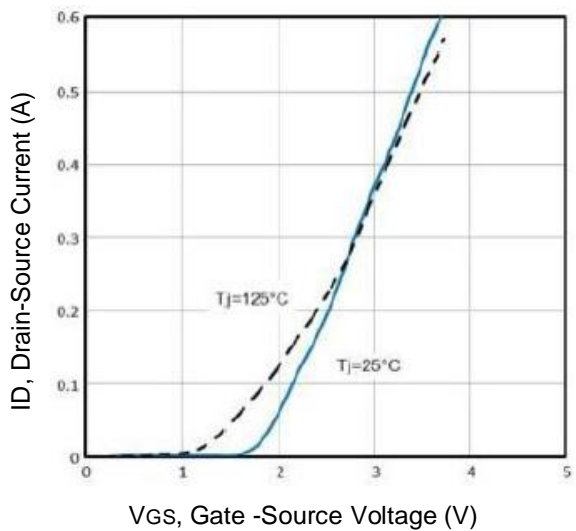

Fig3. Typical Transfer Characteristics

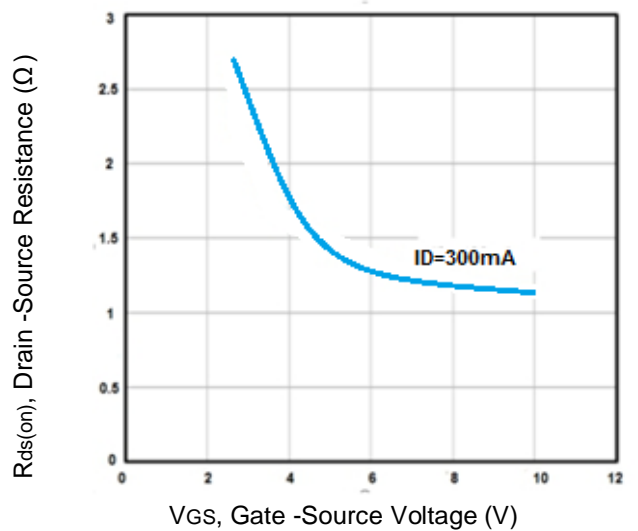

Fig4. $R_{ds(on)}$ vs Gate-Source Voltage

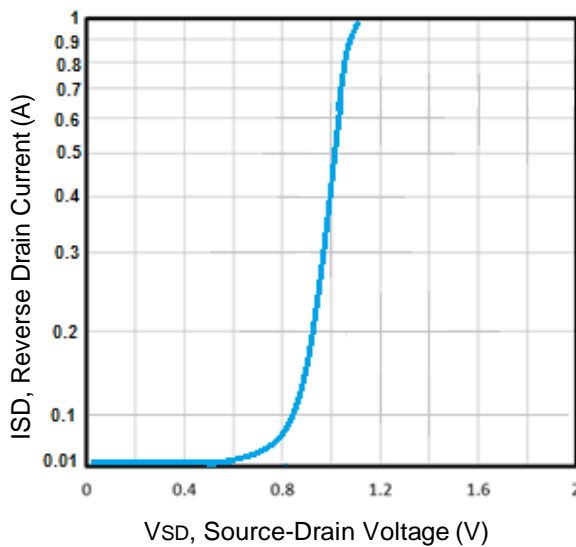

Fig5. Typical Source-Drain Diode Forward Voltage

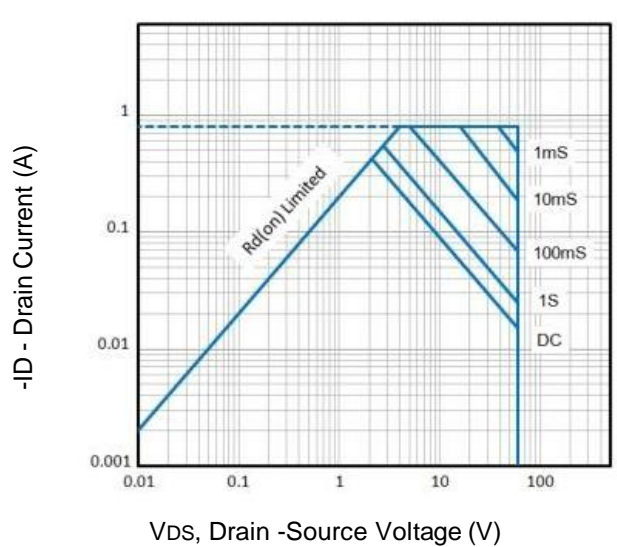

Fig6. Maximum Safe Operating Area

Typical Characteristics

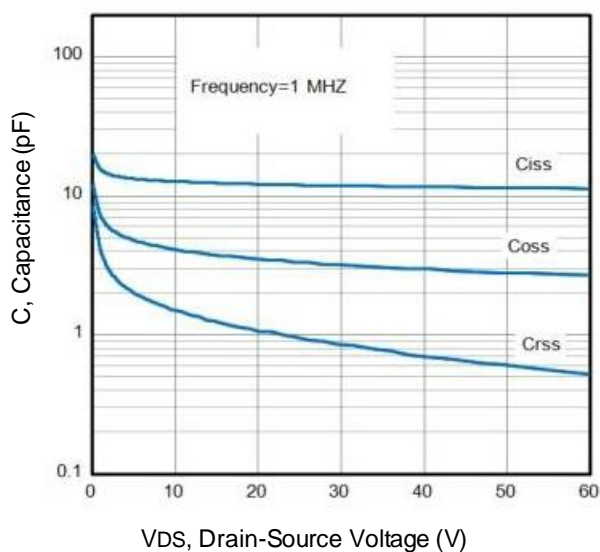

Fig7. Typical Capacitance Vs. Drain-Source Voltage

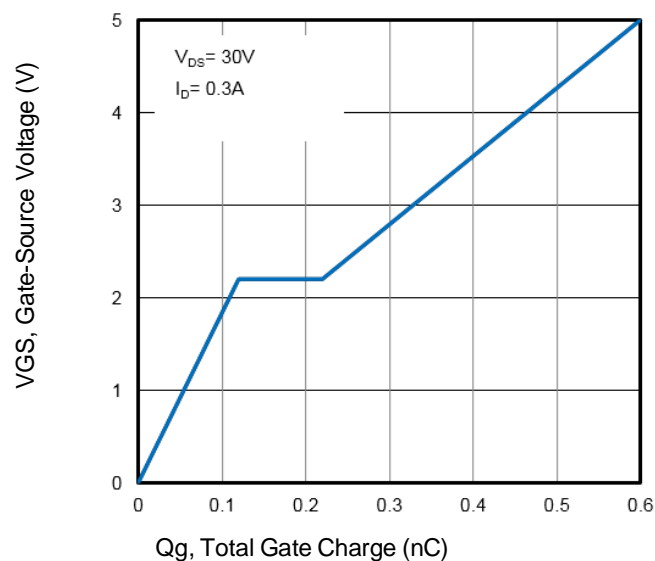

Fig8. Typical Gate Charge Vs. Gate-Source Voltage

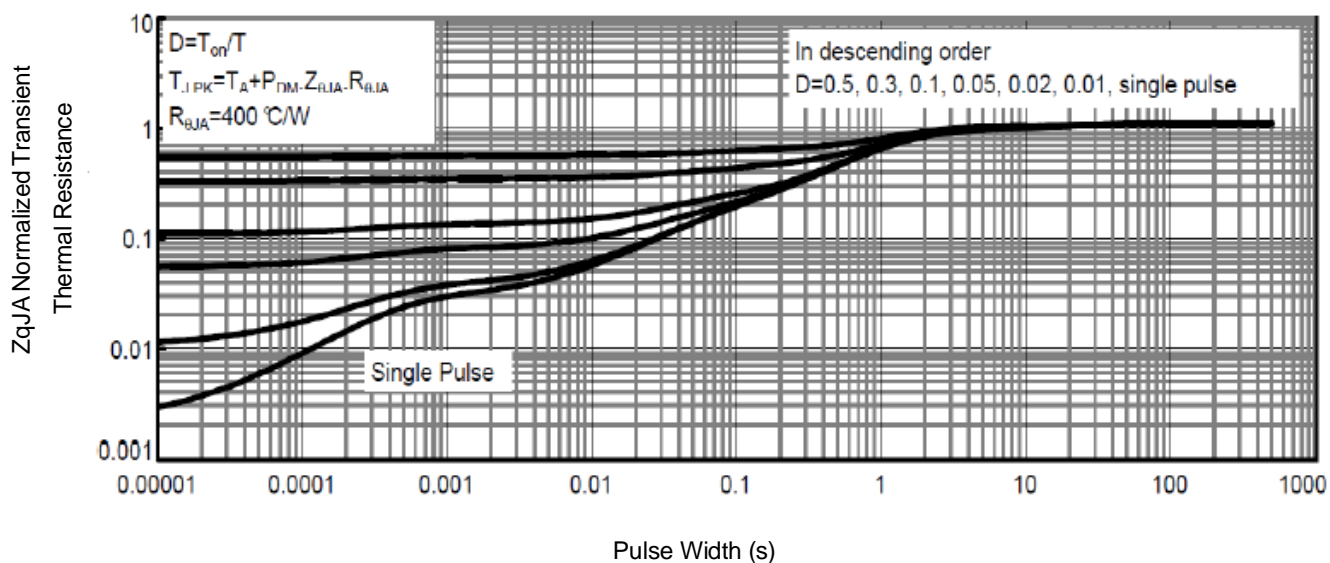

Fig9. Normalized Maximum Transient Thermal Impedance

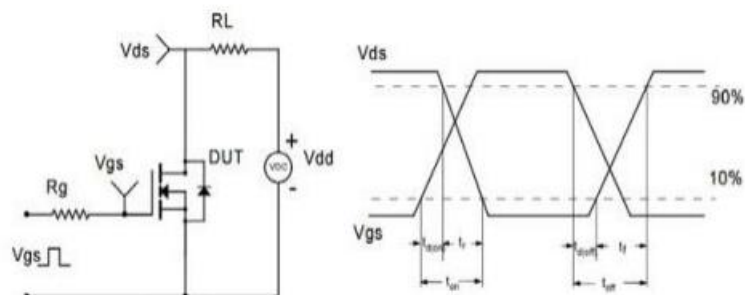
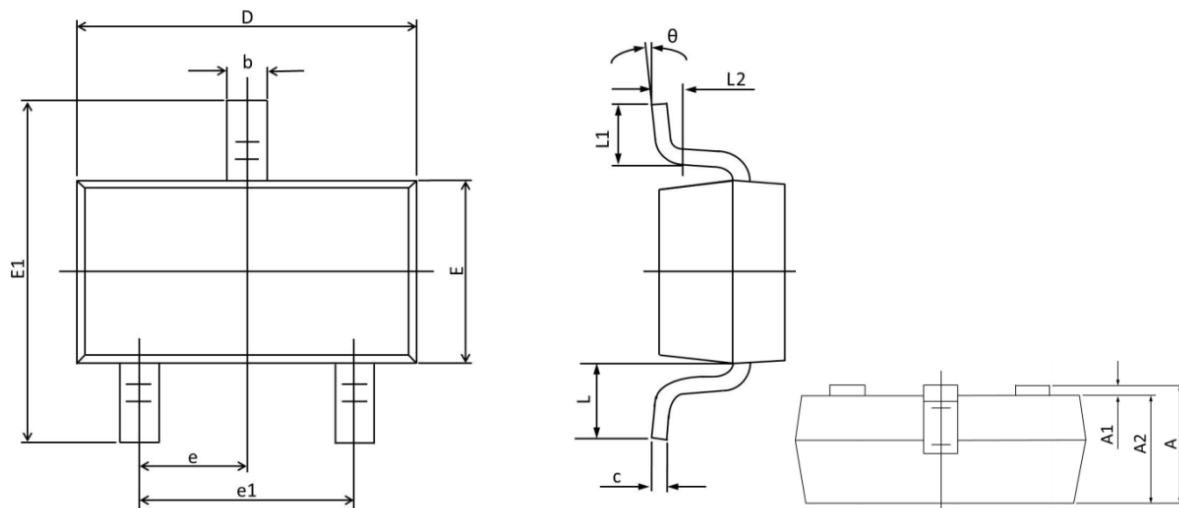

Fig10. Switching Time Test Circuit and waveforms

SOT-323 Mechanica I Data



| Symbol | Dimensions In Millimeters | | Dimensions In Inches | |
|--------|---------------------------|-------|----------------------|-------|
| | MAX | MIN | MAX | MIN |
| A | 1.100 | 0.800 | 0.043 | 0.031 |
| A1 | 0.100 | 0.000 | 0.004 | 0.000 |
| A2 | 1.000 | 0.800 | 0.039 | 0.031 |
| b | 0.400 | 0.200 | 0.016 | 0.008 |
| c | 0.250 | 0.080 | 0.010 | 0.003 |
| D | 2.200 | 1.800 | 0.087 | 0.071 |
| E | 1.350 | 1.150 | 0.053 | 0.045 |
| E1 | 2.450 | 1.800 | 0.096 | 0.071 |
| e | 0.65BSC | | 0.026BSC | |
| e1 | 1.400 | 1.200 | 0.055 | 0.047 |
| L | 0.525REF. | | 0.021REF. | |
| L1 | 0.460 | 0.150 | 0.018 | 0.006 |
| L2 | 0.200 | 0.000 | 0.008 | 0.000 |
| θ | 8° | 0° | 8° | 0° |