

FEATURES

- $R_{DS(ON)} \leq 45m\Omega$ (35m Ω Typ.)
@ $V_{GS}=-4.5V$
- $R_{DS(ON)} \leq 0m\Omega$ (m Ω Typ.)
@ $V_{GS}=-2.5V$
- $R_{DS(ON)} \leq 90m\Omega$ (50m Ω Typ.)
@ $V_{GS}=-1.8V$

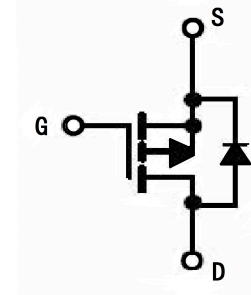

APPLICATIONS

- Load Switch for Portable Devices
- DC/DC Converter

MARKING

- MARKING:3415

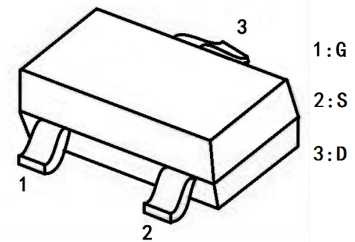

SOT-23

Maximum ratings (Ta=25°C unless otherwise noted)

Symbol	Parameter	Value	Unit
V_{DS}	Drain-Source Voltage	-20	V
V_{GS}	Gate-Source Voltage	± 12	
I_D	Continuous Drain Current	-4.1	A
I_{DM}	Pulsed Drain Current	-16	
P_D	Maximum Power Dissipation	0.83	W
$R_{\theta JA}$	Thermal Resistance from Junction to Ambient(t \leq 5s)	150	$^{\circ}C/W$
T_J	Junction Temperature	150	$^{\circ}C$
T_{stg}	Storage Temperature	-55 ~+150	



MOSFET ELECTRICAL CHARACTERISTICS Ta=25 °C unless otherwise specified

Symbol	Parameter	Test Condition	Min	Typ	Max	Units
Static						
$V_{(BR)DSS}$	Drain-source breakdown voltage	$V_{GS} = 0V, I_D = -250\mu A$	-20	-21.5		V
$V_{GS(th)}$	Gate-source threshold voltage	$V_{DS} = V_{GS}, I_D = -250\mu A$	-0.4	-0.7	-1	
I_{GSS}	Gate-source leakage	$V_{DS} = 0V, V_{GS} = \pm 10V$			± 100	nA
I_{DSS}	Zero gate voltage drain current	$V_{DS} = -16V, V_{GS} = 0V$			-1	μA
$R_{DS(on)}$	Drain-source on-state resistance note1	$V_{GS} = -4.5V, I_D = -3.5A$		35	45	m Ω
		$V_{GS} = -2.5V, I_D = -3A$		38	70	
		$V_{GS} = -1.8V, I_D = -2A$		50	90	
V_{SD}	Body diode voltage	$I_S = -3.3A$		-0.9	-1.2	V
Dynamic ^{note2}						
C_{iss}	Input capacitance	$V_{DS} = -4V, V_{GS} = 0V, f = 1MHz$		740		pF
C_{oss}	Output capacitance			290		
C_{riss}	Reverse transfer capacitance			190		
Q_g	Total gate charge	$V_{DS} = -4V, V_{GS} = -2.5V$ $I_D = -4.1A$		4.5	9	nC
Q_{gs}	Gate-source charge			1.2		
Q_{gd}	Gate-drain charge			1.6		
$t_{d(on)}$	Turn-on delay time	$V_{DS} = -4V,$ $R_L = 1.2\Omega, I_D = -3.3A,$ $V_{GEN} = -4.5V, R_G = 1\Omega$		13	20	nS
t_r	Rise time			35	53	
$t_{d(off)}$	Turn-off delay time			32	48	
t_f	Fall time			10	20	

Notes: 1. Pulse Test : Pulse Width < 300 μs , Duty Cycle $\leq 2\%$.

2 . Guaranteed by design, not subject to production testing.

Typical Performance Characteristics

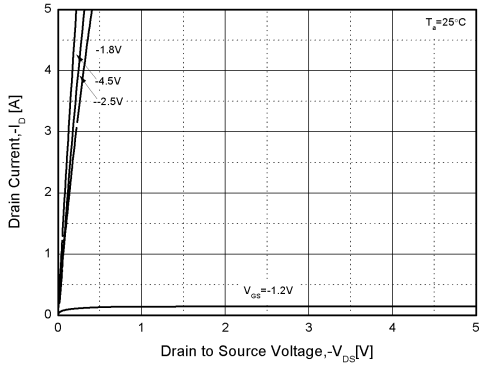

Figure1. Output Characteristics

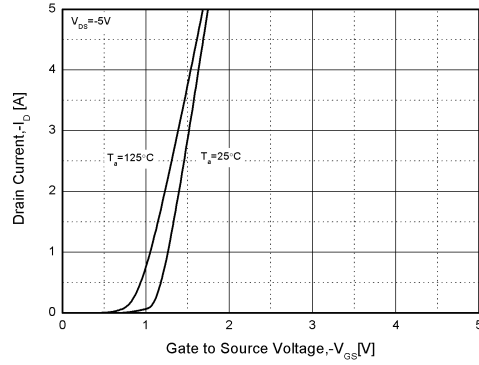

Figure2. Transfer Characteristics

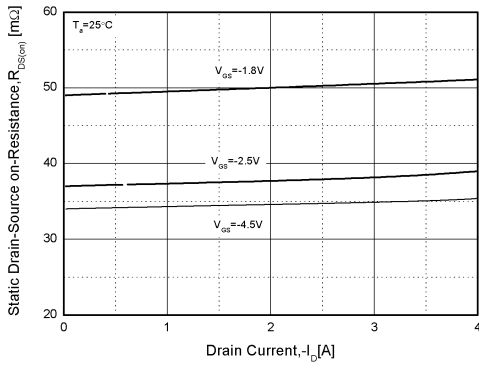

Figure3. Rdson-Drain Current

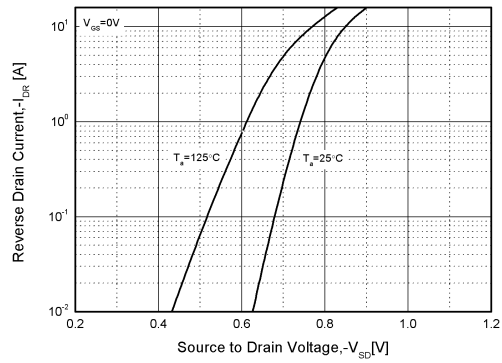

Figure4. Typical Source-Drain Diode Forward Voltage

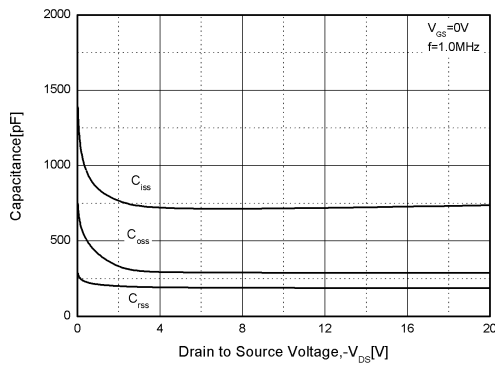

Figure5. Capacitance Characteristics

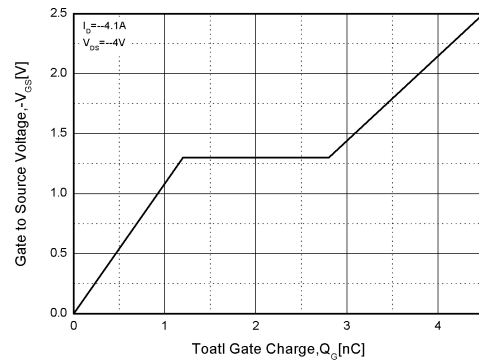

Figure6. Gate Charge

Typical Performance Characteristics (cont.)

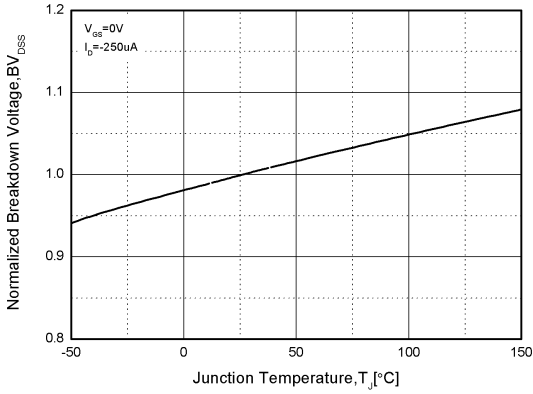

Figure7. Normalized Breakdown Voltage vs. Temperature

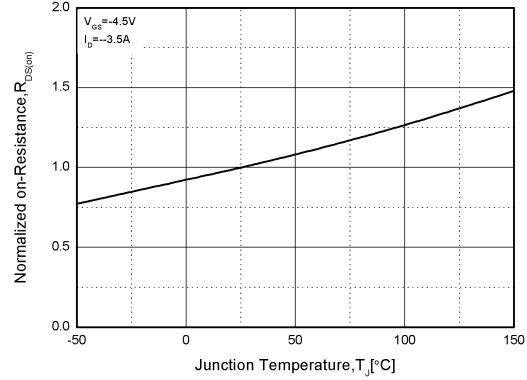

Figure8. Normalized on Resistance vs. Temperature

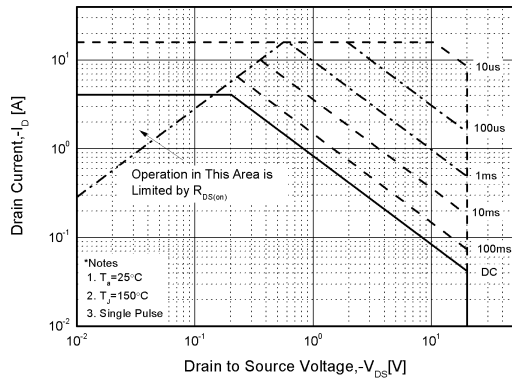

Figure9. Safe Operation Area

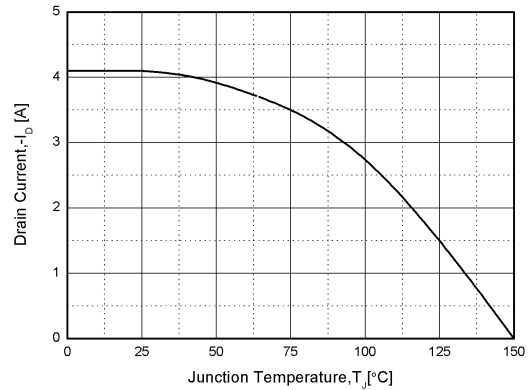
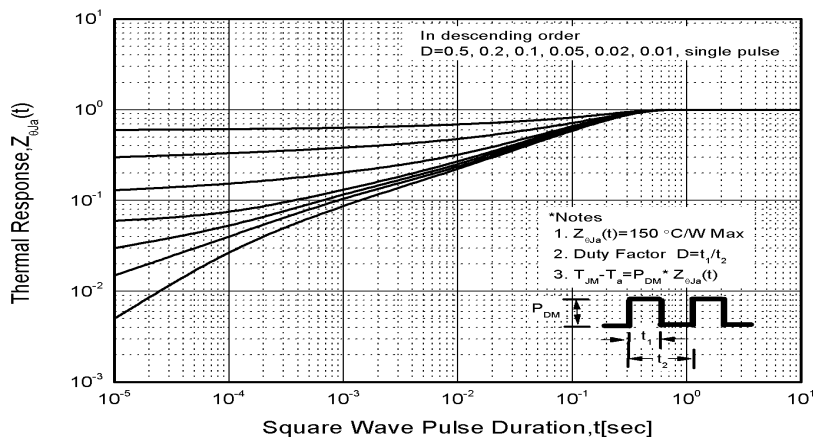

Figure10. Drain Current vs. Case Temperature



PACKAGE OUTLINE

Plastic surface mounted package; 3 leads

SOT-23

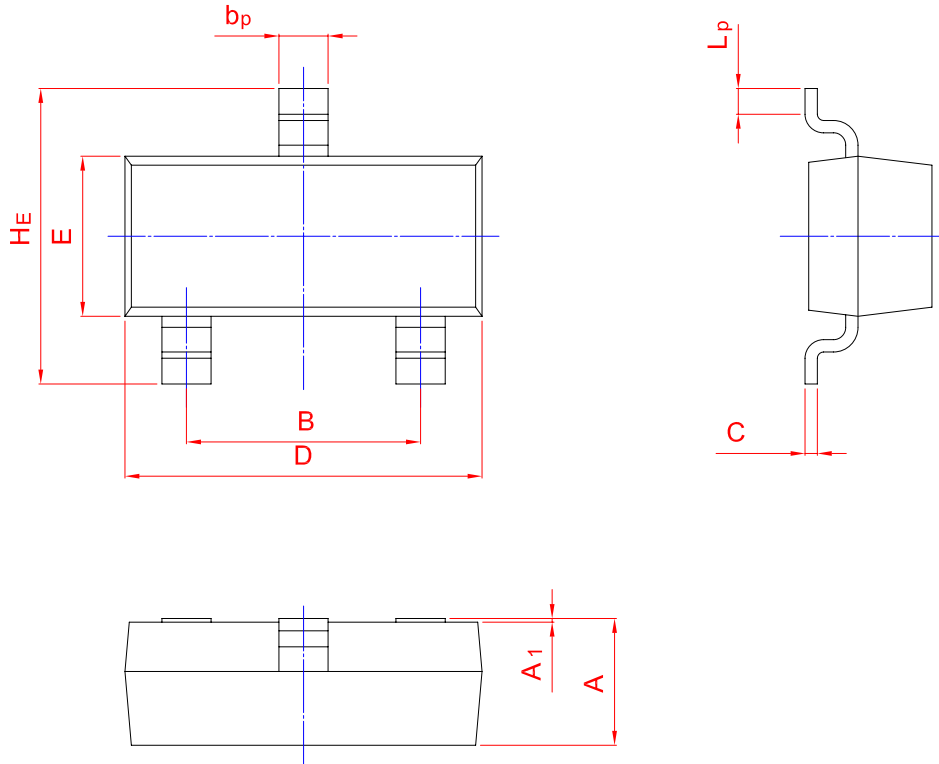
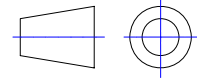

UNIT	A	B	bp	C	D	E	HE	A1	Lp
mm	1.40	2.04	0.50	0.19	3.10	1.65	3.00	0.100	0.50
	0.95	1.78	0.35	0.08	2.70	1.20	2.20	0.013	0.20