



### Features

- Low  $R_{DS(on)}$  @  $V_{GS}=4.5V$
- 3.3V Logic Level Control
- N Channel SOT23 Package
- Pb-Free, RoHS Compliant

### Applications

- Load Switch for
- DC/DC Converter
- Switching Circuits
- LED Driver

$V_{(BR)DSS}$	$R_{DS(ON)}$ Typ	$I_D$ Max
20V	48m $\Omega$ @ 4.5V	3.2A
	55m $\Omega$ @ 3.3V	

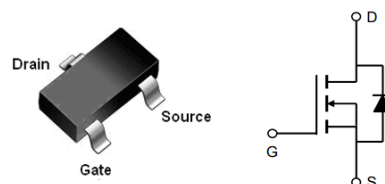

SOT23

### Order Information

Product	Package	Marking	Packing	Min Unit Quantity
LX2302S	SOT23	A2sHB	3000PCS/Reel	3000PCS

### Absolute Maximum Ratings

Stresses exceeding Maximum Ratings may damage the device. Maximum Ratings are stress ratings only. Functional operation above the Recommended Operating Conditions is not implied. Extended exposure to stresses above the Recommended Operating Conditions may affect device reliability.

Parameter	Symbol	Rating	Unit
<b>Common Ratings (<math>T_A=25^\circ\text{C}</math> Unless Otherwise Noted)</b>			
Gate-Source Voltage	$V_{GS}$	$\pm 10$	V
Drain-Source Breakdown Voltage	$V_{(BR)DSS}$	20	V
Maximum Junction Temperature	$T_J$	150	$^\circ\text{C}$
Storage Temperature Range	$T_{STG}$	-50 to 150	$^\circ\text{C}$
<b>Mounted on Large Heat Sink</b>			
Pulse Drain Current Tested <sup>①</sup>	$T_A=25^\circ\text{C}$	$I_{DM}$	12.8 A
Continuous Drain Current	$T_A=25^\circ\text{C}$	$I_D$	3.2 A
	$T_A=70^\circ\text{C}$		2.5 A
Maximum Power Dissipation	$T_A=25^\circ\text{C}$	$P_D$	1 W
	$T_A=70^\circ\text{C}$		0.8 W
Thermal Resistance Junction-Ambient	$R_{\theta JA}$	125	$^\circ\text{C/W}$



Symbol	Parameter	Condition	Min	Typ	Max	Unit
<b>Static Electrical Characteristics @ T<sub>J</sub> = 25°C (unless otherwise stated)</b>						
V <sub>(BR)DSS</sub>	Drain-Source Breakdown Voltage	V <sub>GS</sub> =0V I <sub>D</sub> =250μA	20	--	--	V
I <sub>DSS</sub>	Zero Gate Voltage Drain Current(T <sub>A</sub> =25°C)	V <sub>DS</sub> =20V, V <sub>GS</sub> =0V	--	--	1	μA
	Zero Gate Voltage Drain Current(T <sub>A</sub> =125°C)	V <sub>DS</sub> =16V, V <sub>GS</sub> =0V	--	--	100	uA
I <sub>GSS</sub>	Gate-Body Leakage Current	V <sub>GS</sub> =±10V, V <sub>DS</sub> =0V	--	--	±100	nA
V <sub>GS(TH)</sub>	Gate Threshold Voltage	V <sub>DS</sub> =V <sub>GS</sub> , I <sub>D</sub> =250μA	0.4	0.6	1.0	V
R <sub>DS(ON)</sub>	Drain-Source On-State Resistance <sup>②</sup>	V <sub>GS</sub> =4.5V, I <sub>D</sub> =3A	--	48	60	mΩ
R <sub>DS(ON)</sub>	Drain-Source On-State Resistance <sup>②</sup>	V <sub>GS</sub> =3.3V, I <sub>D</sub> =2A	--	55	70	mΩ
R <sub>DS(ON)</sub>	Drain-Source On-State Resistance <sup>②</sup>	V <sub>GS</sub> =2.5V, I <sub>D</sub> =1A	--	66	80	mΩ
<b>Dynamic Electrical Characteristics @ T<sub>J</sub> = 25°C (unless otherwise stated)</b>						
C <sub>iss</sub>	Input Capacitance	V <sub>DS</sub> =10V, V <sub>GS</sub> =0V, f=1MHz	--	160	--	pF
C <sub>oss</sub>	Output Capacitance		--	30	--	pF
C <sub>rss</sub>	Reverse Transfer Capacitance		--	25	--	pF
Q <sub>g</sub>	Total Gate Charge	V <sub>DS</sub> =10V I <sub>D</sub> =3A, V <sub>GS</sub> =5V	--	4.0	--	nC
Q <sub>gs</sub>	Gate Source Charge		--	0.4	--	nC
Q <sub>gd</sub>	Gate Drain Charge		--	1.2	--	nC
<b>Switching Characteristics</b>						
t <sub>d(on)</sub>	Turn on Delay Time	V <sub>DD</sub> =10V, I <sub>D</sub> =2A, R <sub>G</sub> =3.3Ω, V <sub>GS</sub> =4.5V	--	8	--	ns
t <sub>r</sub>	Turn on Rise Time		--	30	--	ns
t <sub>d(off)</sub>	Turn Off Delay Time		-	19	--	ns
t <sub>f</sub>	Turn Off Fall Time		--	28	--	ns
<b>Source Drain Diode Characteristics</b>						
I <sub>SD</sub>	Source drain current(Body Diode)	T <sub>A</sub> =25°C	--	--	1.5	A
V <sub>SD</sub>	Forward on voltage <sup>②</sup>	T <sub>J</sub> =25°C, I <sub>SD</sub> =1A, V <sub>GS</sub> =0V	--	0.82	1.2	V

**Notes:**

① Pulse width limited by maximum allowable junction temperature

Typical Characteristics

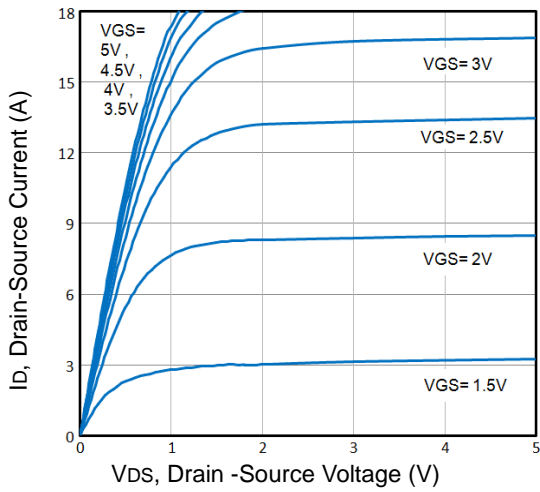

Fig1. Typical Output Characteristics

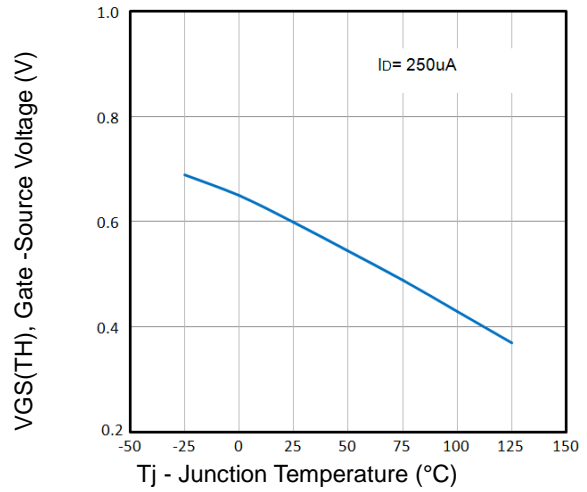

Fig2. Normalized Threshold Voltage Vs. Temperature

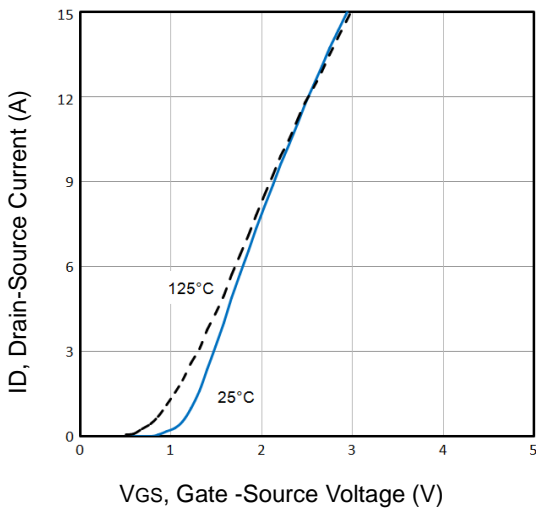

Fig3. Typical Transfer Characteristics

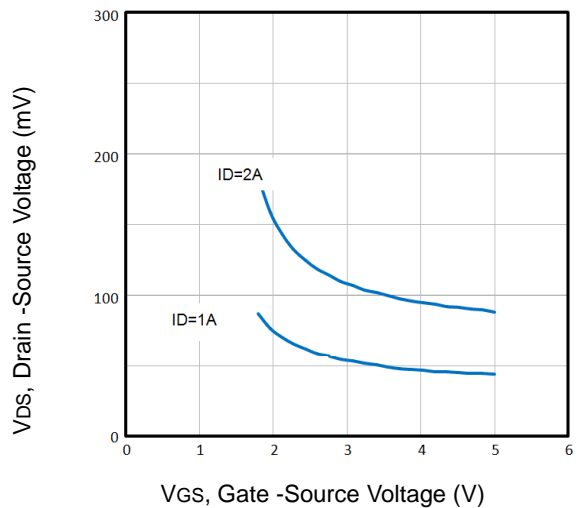

Fig4. Drain-Source Voltage vs Gate-Source Voltage

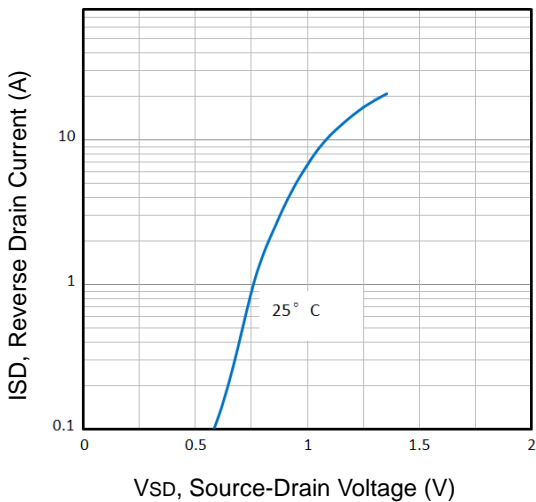

Fig5. Typical Source-Drain Diode Forward Voltage

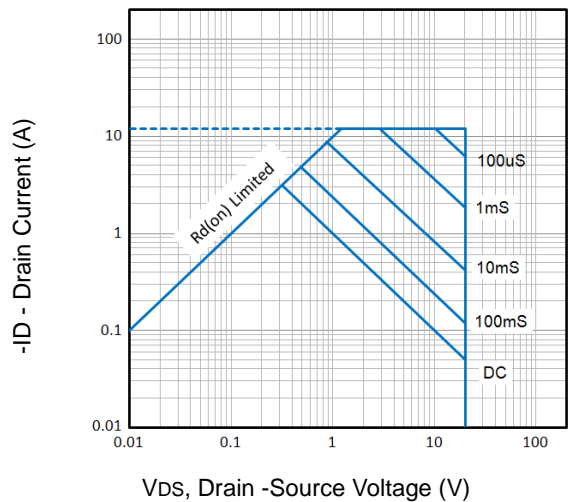

Fig6. Maximum Safe Operating Area

Typical Characteristics

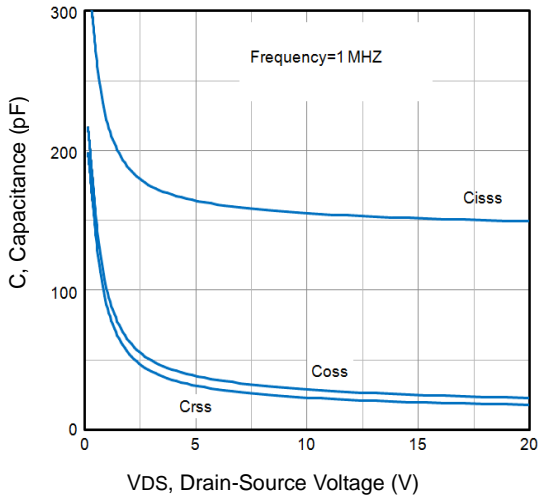

Fig7. Typical Capacitance Vs. Drain-Source Voltage

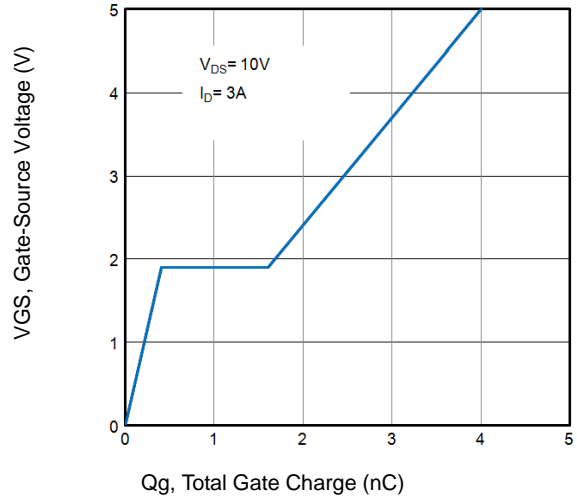

Fig8. Typical Gate Charge Vs. Gate-Source Voltage

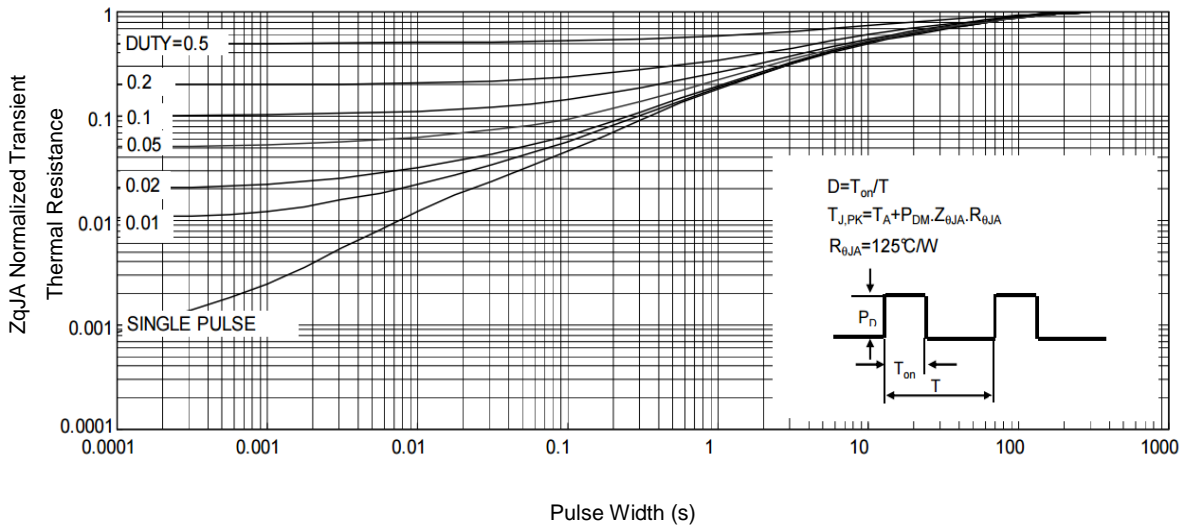

Fig9. Normalized Maximum Transient Thermal Impedance

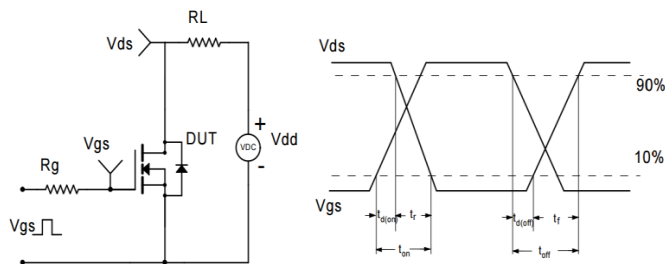
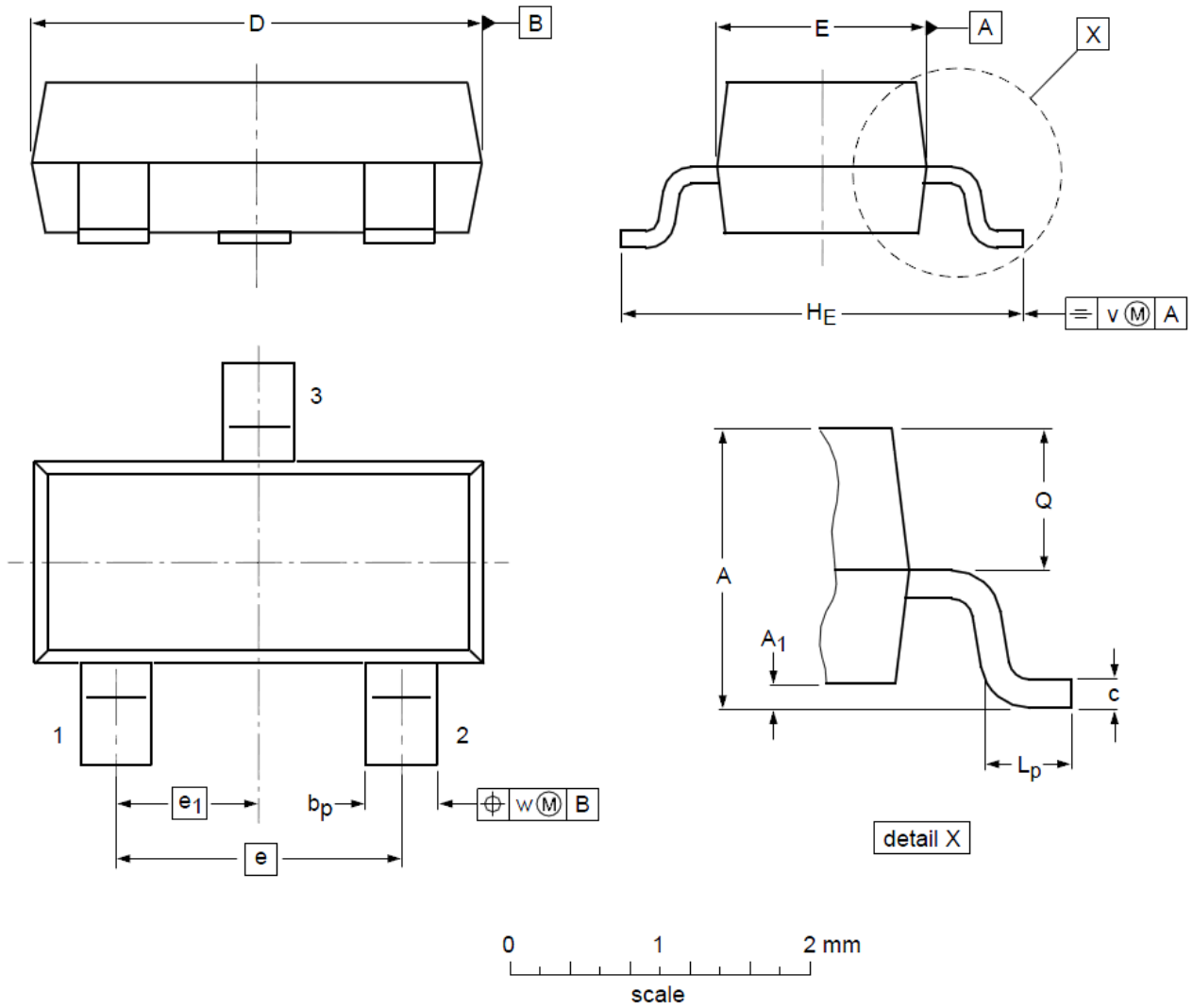

Fig10. Switching Time Test Circuit and waveforms

**SOT23 Mechanical Data**



**DIMENSIONS ( unit : mm )**

Symbol	Min	Typ	Max	Symbol	Min	Typ	Max
<b>A</b>	0.90	1.01	1.15	<b>A<sub>1</sub></b>	0.01	0.05	0.10
<b>b<sub>p</sub></b>	0.30	0.42	0.50	<b>c</b>	0.08	0.13	0.15
<b>D</b>	2.80	2.92	3.00	<b>E</b>	1.20	1.33	1.40
<b>e</b>	--	1.90	--	<b>e<sub>1</sub></b>	--	0.95	--
<b>H<sub>E</sub></b>	2.25	2.40	2.55	<b>L<sub>p</sub></b>	0.30	0.42	0.50
<b>Q</b>	0.45	0.49	0.55	<b>v</b>	--	0.20	--
<b>w</b>	--	0.10	--				