

FEATURE

- Lead Free Product is Acquired
- Surface Mount Package
- P-Channel Switch with Low $R_{DS(on)}$
- Operated at Low Logic Level Gate Drive

P-Channel MOSFET

$V_{(BR)DSS}$	$R_{DS(on)MAX}$	I_D
-20V	520mΩ@-4.5V	-0.66A
	700mΩ@-2.5V	
	950mΩ(TYP)@-1.8V	

MARKING

- MARKING:KD

APPLICATION

- Load/Power Switching
- Interfacing, Logic Switching
- Battery Management for Ultra Small Portable Electronics

SOT-723

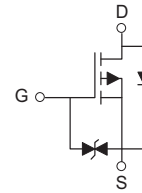
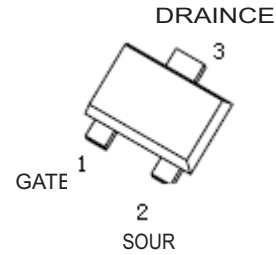

Maximum ratings($T_a=25^\circ\text{C}$ unless otherwise noted)

Parameter	Symbol	Value	Unit
Drain-Source Voltage	V_{DS}	-20	V
Typical Gate-Source Voltage	V_{GS}	± 12	V
Continuous Drain Current(note 1)	I_D	-0.66	A
Pulsed Drain Current ($t_p=10\mu\text{s}$)	I_{DM}	-1.2	A
Power Dissipation (note 1)	P_D	150	mW
Thermal Resistance from Junction to Ambient (note 1)	$R_{\theta JA}$	833	$^\circ\text{C/W}$
Operation Junction and Storage Temperature Range	T_J, T_{STG}	-55~+150	$^\circ\text{C}$
Lead Temperature for Soldering Purposes(1/8" from case for 10 s)	T_L	260	$^\circ\text{C}$



MOSFET ELECTRICAL CHARACTERISTICS

T_a=25°C unless otherwise specified

Parameter	Symbol	Test Condition	Min	Typ	Max	Unit	
STATIC CHARACTERISTICS							
Drain-source breakdown voltage	V _{(BR)DSS}	V _{GS} = 0V, I _D = -250μA	-20			V	
Zero gate voltage drain current	I _{DSS}	V _{DS} = -20V, V _{GS} = 0V			-1	μA	
Gate-body leakage current	I _{GSS}	V _{GS} = ±10V, V _{DS} = 0V			±20	μA	
Gate threshold voltage (note 2)	V _{GS(th)}	V _{DS} = V _{GS} , I _D = -250μA	-0.35	-0.45	-1.1	V	
Drain-source on-resistance (note 2)	R _{DS(on)}	V _{GS} = -4.5V, I _D = -1A		430	520	mΩ	
		V _{GS} = -2.5V, I _D = -0.8A		624	700	mΩ	
		V _{GS} = -1.8V, I _D = -0.5A		950		mΩ	
Forward transconductance (note 2)	g _{FS}	V _{DS} = -10V, I _D = -0.54A		1.2		S	
Diode forward voltage	V _{SD}	I _S = -0.5A, V _{GS} = 0V			-1.2	V	
DYNAMIC CHARACTERISTICS (note 4)							
Input capacitance	C _{iss}	V _{DS} = -16V, V _{GS} = 0V, f = 1MHz		113	170	pF	
Output capacitance	C _{oss}			15	25	pF	
Reverse transfer capacitance	C _{rss}			9	15	pF	
SWITCHING CHARACTERISTICS (note 4)							
Turn-on delay time (note 3)	t _{d(on)}	V _{GS} = -4.5V, V _{DS} = -10V, I _D = -200mA, R _{GEN} = 10Ω		9		ns	
Turn-on rise time (note 3)	t _r			5.8		ns	
Turn-off delay time (note 3)	t _{d(off)}				32.7		ns
Turn-off fall time (note 3)	t _f				20.3		ns

Notes:

1. Surface mounted on FR4 board using the minimum recommended pad size.
2. Pulse Test : Pulse Width=300μs, Duty Cycle=2%.
3. Switching characteristics are independent of operating junction temperatures.
4. Guaranteed by design, not subject to producing.



Output Characteristics

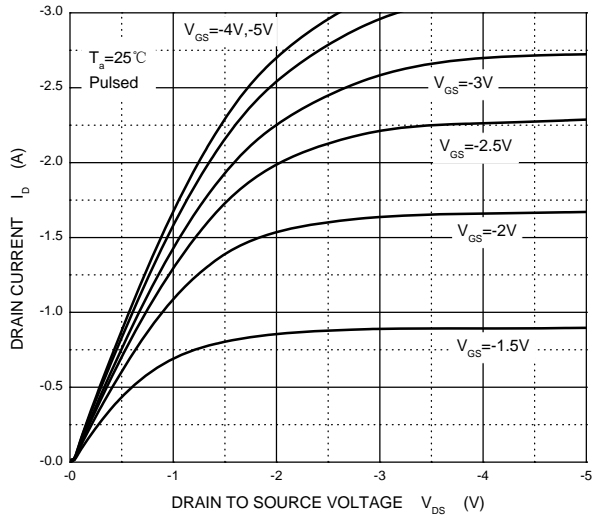

Transfer Characteristics

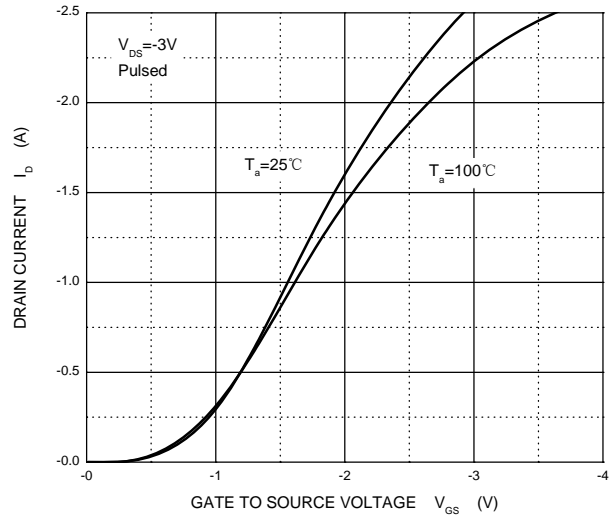

$R_{DS(ON)}$ — I_D

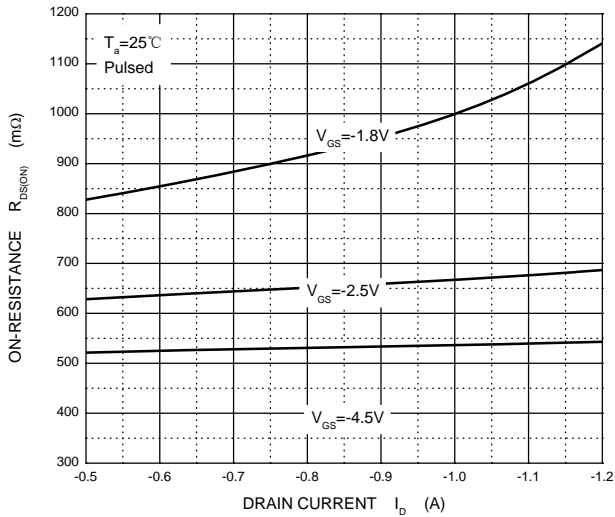

$R_{DS(ON)}$ — V_{GS}

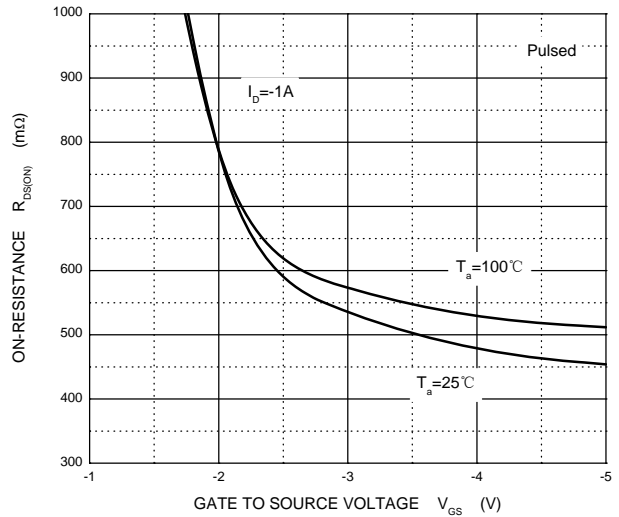

I_S — V_{SD}

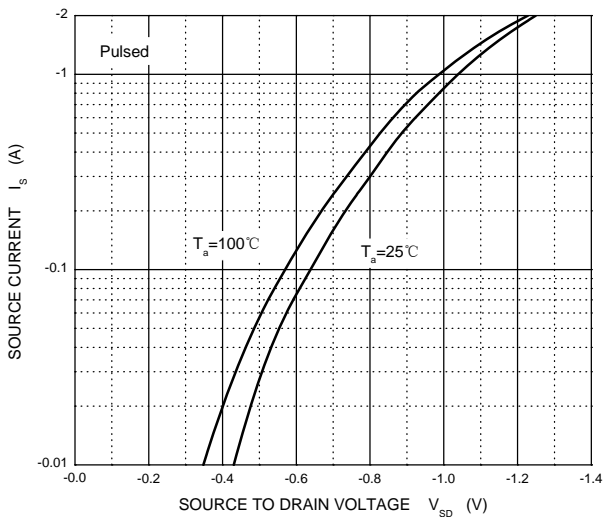

Threshold Voltage

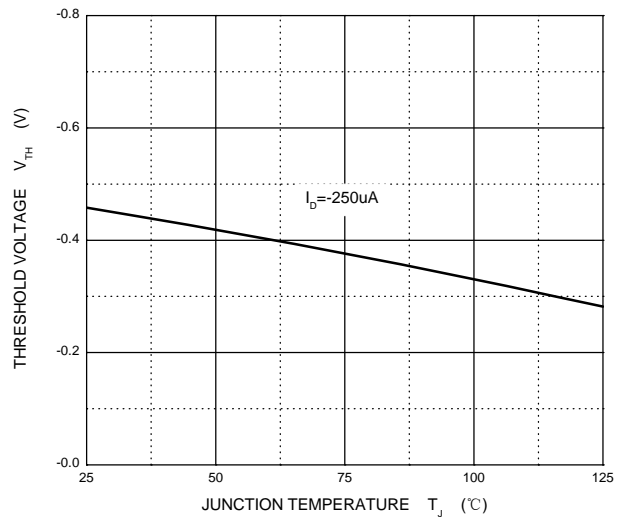

SOT-723 Package Outline Dimensions

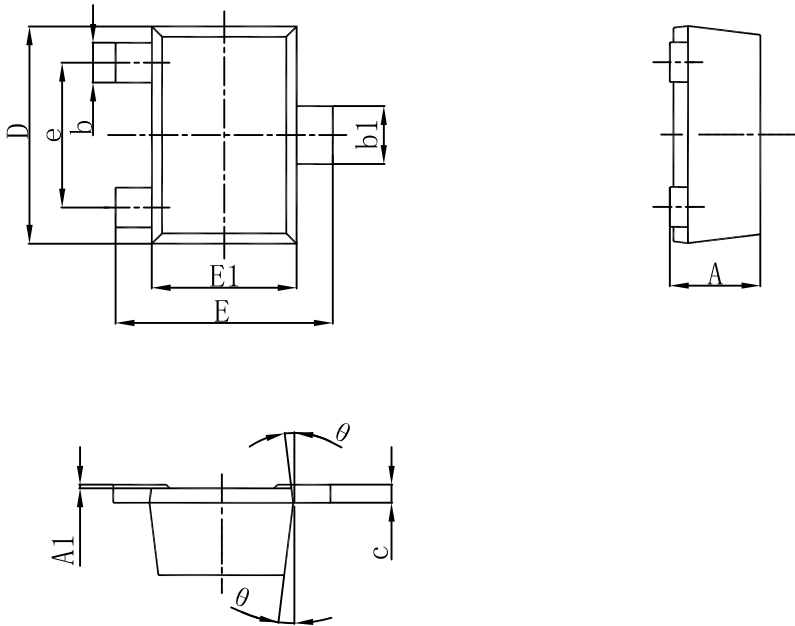

Symbol	Dimensions In Millimeters		Dimensions In Inches	
	Min.	Max.	Min.	Max.
A	0.450	0.550	0.018	0.022
A1	0.000	0.050	0.000	0.002
b	0.170	0.270	0.007	0.011
b1	0.270	0.370	0.011	0.015
c	0.080	0.150	0.003	0.006
D	1.150	1.250	0.045	0.049
E	1.150	1.250	0.045	0.049
E1	0.750	0.850	0.030	0.033
e	0.800TYP.		0.031TYP.	
θ	7° REF.		7° REF.	

SOT-723 Suggested Pad Layout

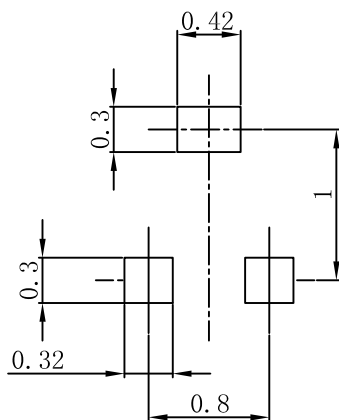

Note:
 1. Controlling dimension: in millimeters.
 2. General tolerance: ± 0.05mm.
 3. The pad layout is for reference purposes only.