



Features

- 60Watts peak pulse power ($t_p = 8/20\mu s$)
- Uni-directional configurations
- Solid-state silicon-avalanche technology
- Capacitance: 0.45pF typical
- Low clamping voltage
- Low leakage current
- Complies with following standards:
 - IEC 61000-4-2 (ESD) immunity test
 - Air discharge: $\pm 25KV$
 - Contact discharge: $\pm 20KV$
 - IEC61000-4-4 (EFT) 40A (5/50ns)
 - IEC61000-4-5 (Lightning) 4A (8/20us)

Applications

- HDMI 1.3 & 1.4, USB 2.0 & 3.0 and MDDI ports
- Set-top box and digital TV
- Video graphics cards
- Digital video interface(DVI)
- Notebook Computers
- PCI express and Serial SATA ports

Schematic & PIN Configuration

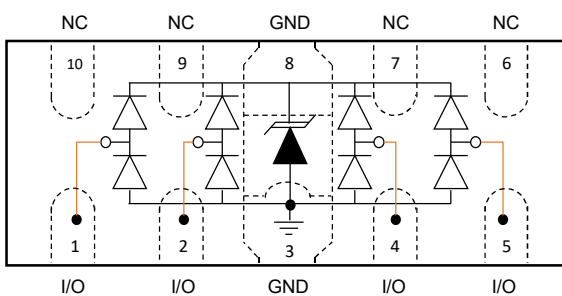

DFN2510P10

DFN10L

1mm×2.5mm×0.5mm

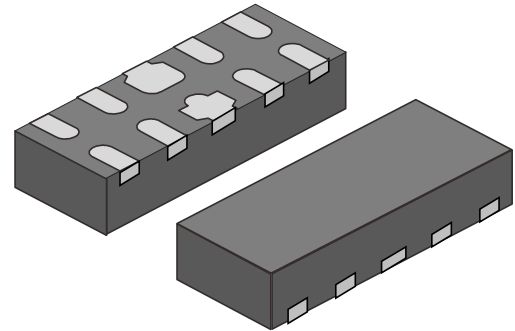

Mechanical Data

- Package: DFN2510P10
- UL Flammability Classification Rating 94V-0
- Packaging: Tape and Reel
- RoHS/WEEE Compliant

Marking

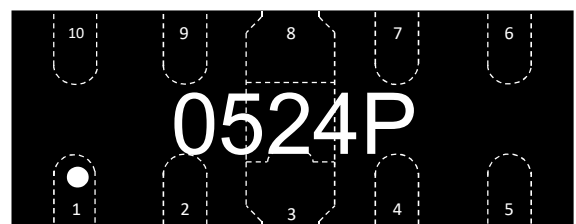

Absolute Maximum Ratings

Parameter	Symbol	Value	Units
Reverse Working Voltage	V_{RWM}	5	V
Peak Pulse Power (tp=8/20μs)	P_{PP}	60	W
Peak Pulse Current (tp=8/20μs)	I_{PP}	4	A
ESD per IEC 61000-4-2 (Air)	$V_{ESD-Air}$	25	KV
ESD per IEC 61000-4-2 (Contact)	$V_{ESD-Contact}$	20	KV
Lead Soldering Temperature (10s)	T_L	260	°C
Operating Temperature Range	T_J	-55 to 125	°C
Storage Temperature Range	T_{STG}	-55 to 150	°C

Electrical Characteristics

Parameter	Symbol	Conditions	Min	Typ	Max	Units
Breakdown Voltage	V_{BR}	$I_T = 1mA$	6	7		V
Reverse Leakage Current	I_R	$V_{RWM} = 5V$		0.001	0.1	uA
Clamping Voltage	V_C	$I_{PP} = 1A, tp=8/20\mu s$		8		V
		$I_{PP} = 4A, tp=8/20\mu s$		12	14	V
Junction Capacitance between I/O pins	C_J	$V_{DC} = 0V, f=1MHz$		0.25	0.4	pF
Junction Capacitance	C_J	$V_{DC} = 0V, f=1MHz$		0.45	0.8	pF

Electrical Parameters

Symbol	Definition
I_{PP}	Peak Pulse Current
V_C	Clamping Voltage
V_{RWM}	Reverse Working Voltage
I_R	Reverse Leakage Current
V_{BR}	Breakdown Voltage
I_T	Test Current
V_F	Forward Voltage
I_F	Forward Current

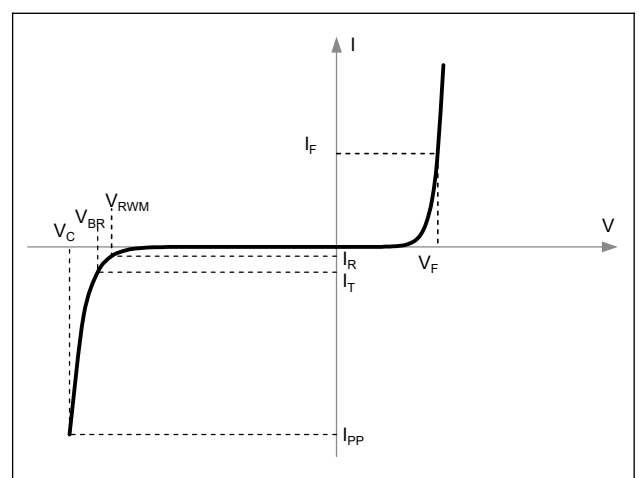

Typical Characteristics

Fig.1 - Peak Pulse Power Rating

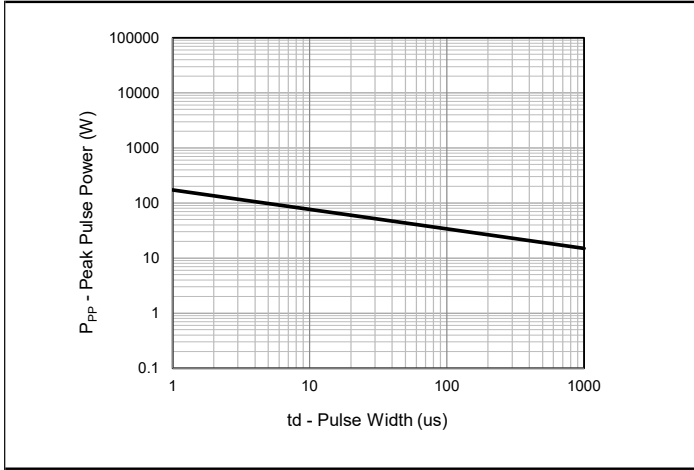

Fig.2 - Pulse Derating Curve

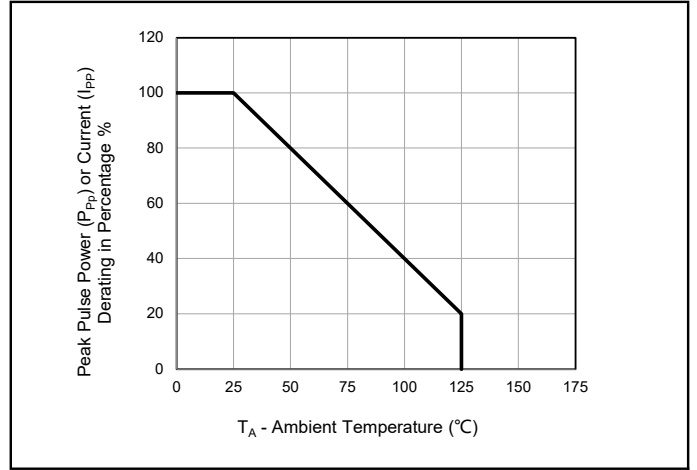

Fig.3 - 8/20us Pulse Waveform

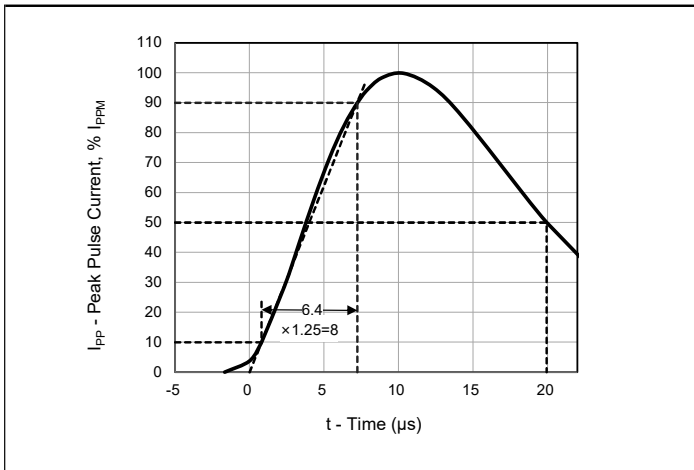

Fig.4 - Typical Clamping Voltage

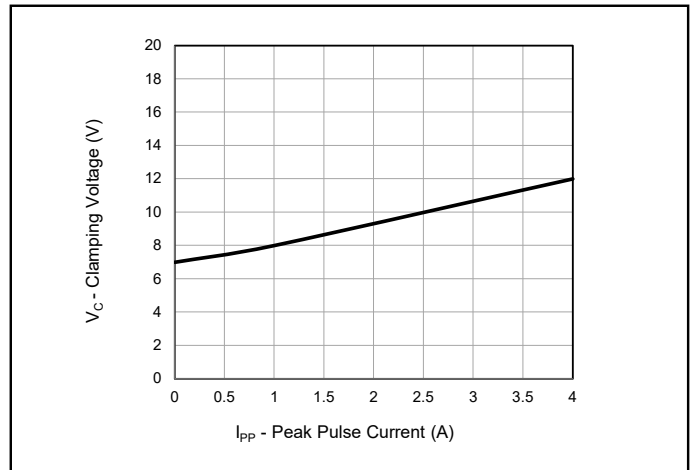

Fig.5 - ESD Pulse Waveform (IEC61000-4-2)

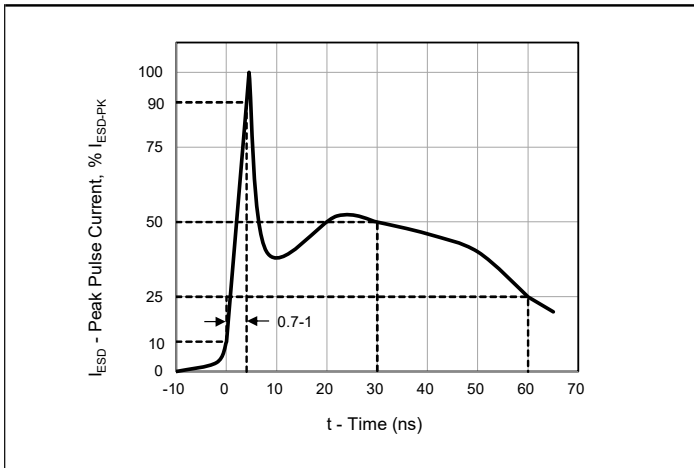
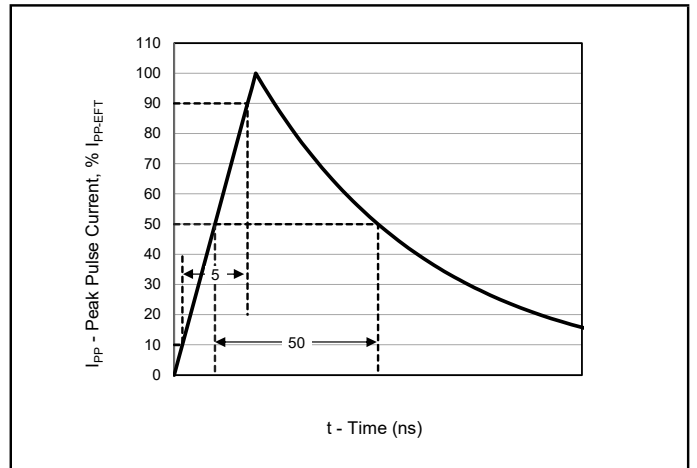
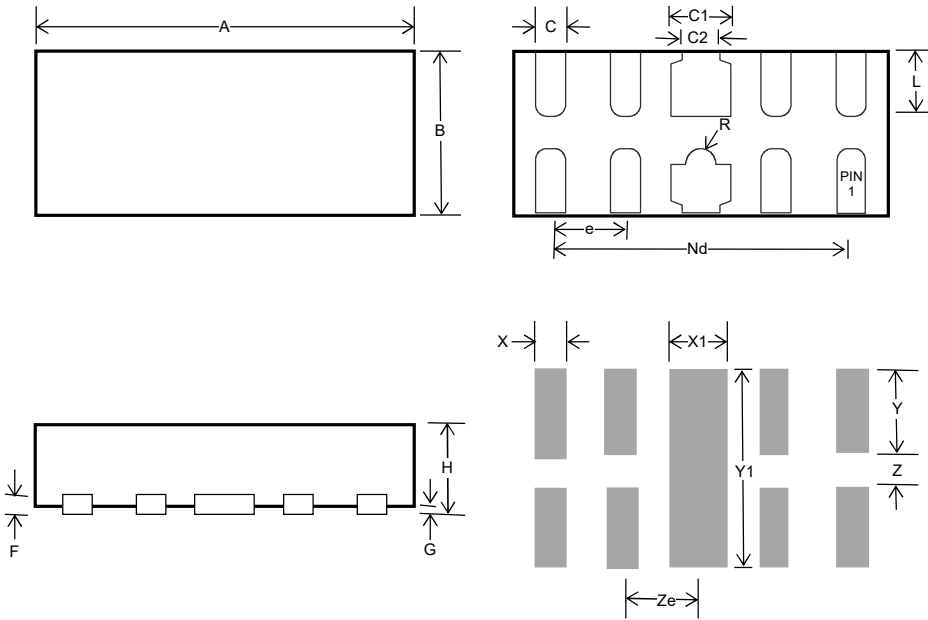

Fig.6 - 5/50ns EFT Waveform (IEC61000-4-4)



Outline Drawing



DFN2510P10			
SYMBOL	Millimeters		
	MIN	NOM	MAX
A	2.45	2.5	2.55
B	0.95	1	1.05
C	0.15	0.2	0.25
F	0.119	0.127	0.135
G	-	0.02	0.05
H	0.45	0.5	0.6
L	0.35	0.4	0.45
e		0.5	
C1	0.35	0.4	0.45
C2	0.2		0.3
R	0.05		0.15
Nd		2	
X		0.2	
Y		0.6	
Z		0.2	
Ze		0.5	
X1		0.4	
Y1		1.4	

Ordering Information

Order Code	Package	Base Quantity	Delivery Mode
LXE2510F5VUL	DFN2510P10	3000 PCS/Reel	Tape and Reel