

## Features

- Complementary To S8050.
- Collector current:  $I_C=0.5A$

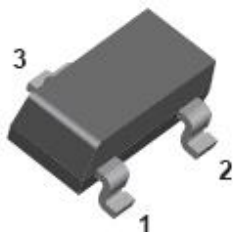

1.BASE  
2.EMITTER  
3.COLLECTO

## Applications

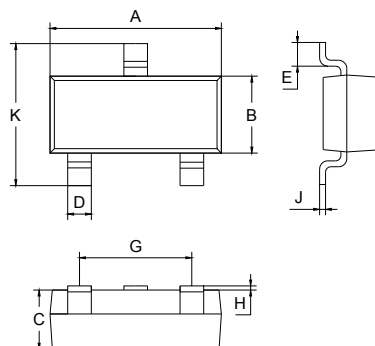

SOT-23		
Dim	Min	Max
A	2.70	3.10
B	1.10	1.50
C	1.0 Typical	
D	0.4 Typical	
E	0.35	0.48
G	1.80	2.00
H	0.02	0.1
J	0.1 Typical	
K	2.20	2.60
All Dimensions in mm		

## Ordering Information

Type No.	Marking	Package Code
S8550	2TY	SOT-23

## MAXIMUM RATING @ $T_a=25^\circ C$ unless otherwise noted

Symbol	Parameter	Value	Unit
$V_{CBO}$	Collector-Base Voltage	-40	V
$V_{CEO}$	Collector-Emitter Voltage	-25	V
$V_{EBO}$	Emitter-Base Voltage	-5	V
$I_c$	Collector Current -Continuous	-0.5	A
$P_c$	Collector Power Dissipation	0.3	W
$T_J, T_{stg}$	Operation Junction and Storage Temperature Range	-55-150	$^\circ C$



**ELECTRICAL CHARACTERISTICS @  $T_a=25^\circ\text{C}$  unless otherwise specified**

Parameter	Symbol	Test conditions	Min	Max	Unit
Collector-base breakdown voltage	$V_{(BR)CBO}$	$I_C = -100\mu\text{A}, I_E = 0$	-40		V
Collector-emitter breakdown voltage	$V_{(BR)CEO}$	$I_C = -1\text{mA}, I_B = 0$	-25		V
Emitter-base breakdown voltage	$V_{(BR)EBO}$	$I_E = -100\mu\text{A}, I_C = 0$	-5		V
Collector cut-off current	$I_{CBO}$	$V_{CB} = -40\text{V}, I_E = 0$		-0.1	$\mu\text{A}$
Collector cut-off current	$I_{CEO}$	$V_{CE} = -20\text{V}, I_B = 0$		-0.1	$\mu\text{A}$
Emitter cut-off current	$I_{EBO}$	$V_{EB} = -3\text{V}, I_C = 0$		-0.1	$\mu\text{A}$
DC current gain	$h_{FE(1)}$	$V_{CE} = -1\text{V}, I_C = -50\text{mA}$	120	400	
	$h_{FE(2)}$	$V_{CE} = -1\text{V}, I_C = -500\text{mA}$	50		
Collector-emitter saturation voltage	$V_{CE(sat)}$	$I_C = -500\text{mA}, I_B = -50\text{mA}$		-0.6	V
Base-emitter saturation voltage	$V_{BE(sat)}$	$I_C = -500\text{mA}, I_B = -50\text{mA}$		-1.2	V
Transition frequency	$f_T$	$V_{CE} = -6\text{V}, I_C = -20\text{mA}$ $f = 30\text{MHz}$	150		MHz

**CLASSIFICATION OF  $h_{FE(1)}$**

RANK	L	H	J
RANGE	120 – 200	200 – 350	300 – 400



**TYPICAL CHARACTERISTICS**

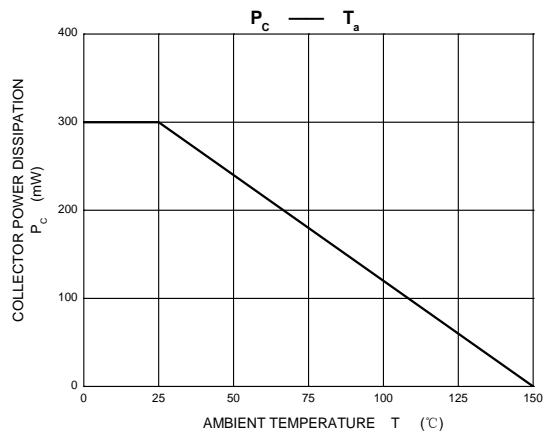
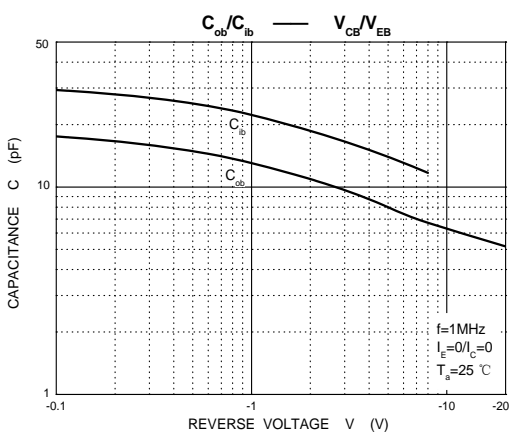
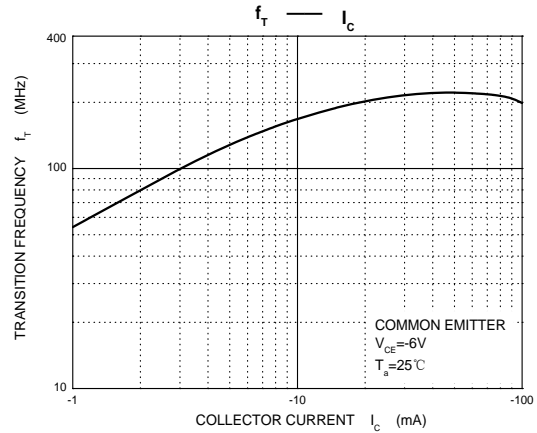
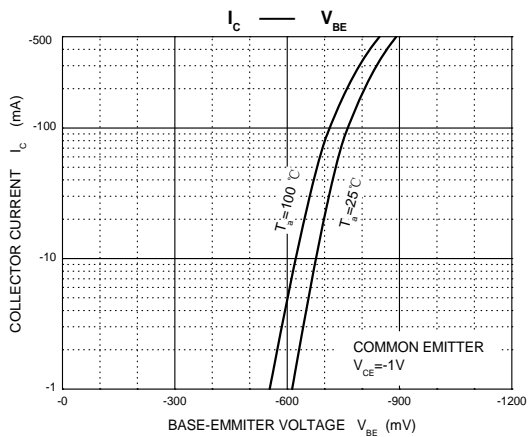
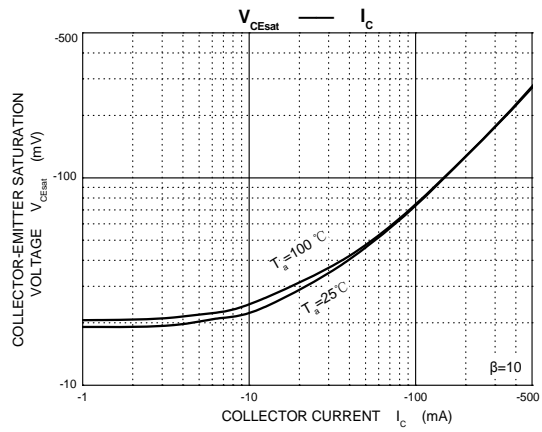
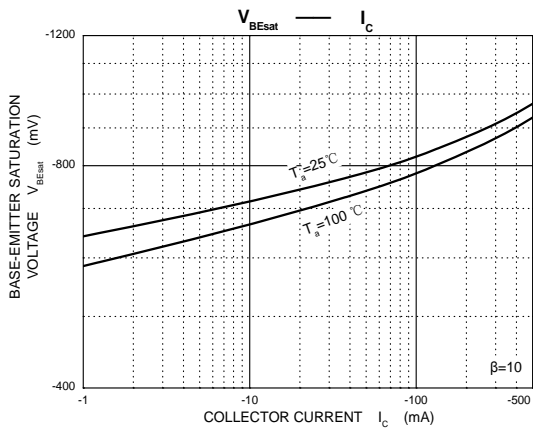
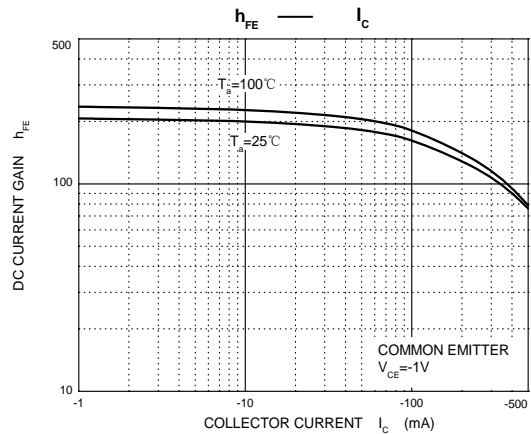
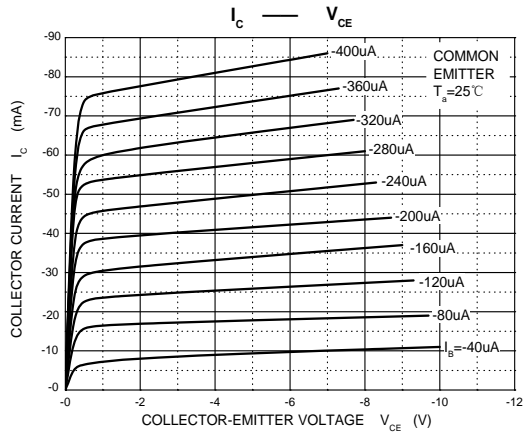

**SOT-23 Tape and Reel**

**SOT-23 Embossed Carrier Tape**

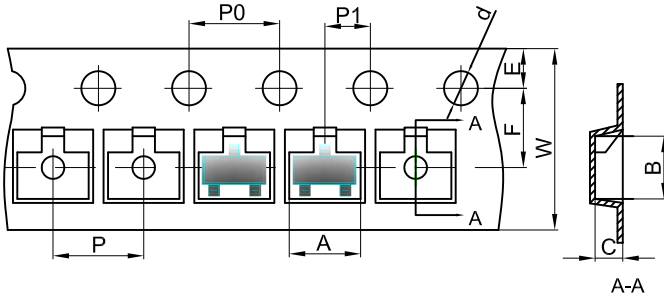

**Packaging Description:**  
SOT-23 parts are shipped in tape. The carrier tape is made from a dissipative (carbon filled) polycarbonate resin. The cover tape is a multilayer film (Heat Activated Adhesive in nature) primarily composed of polyester film, adhesive layer, sealant, and anti-static sprayed agent. These reeled parts in standard option are shipped with 3,000 units per 7" or 17.8cm diameter reel. The reels are clear in color and is made of polystyrene plastic (anti-static coated).

Dimensions are in millimeter											
Pkg type	A	B	C	d	E	F	P0	P	P1	W	
SOT-23	3.15	2.77	1.22	Ø1.50	1.75	3.50	4.00	4.00	2.00	8.00	

**SOT-23 Tape Leader and Trailer**

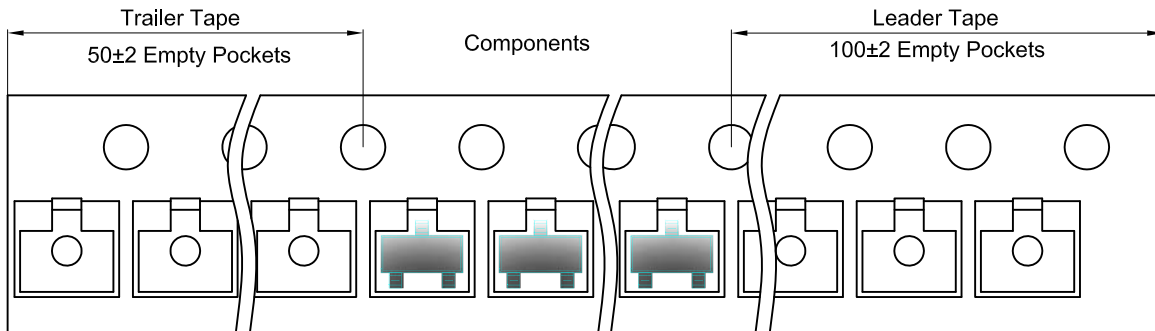

**SOT-23 Reel**

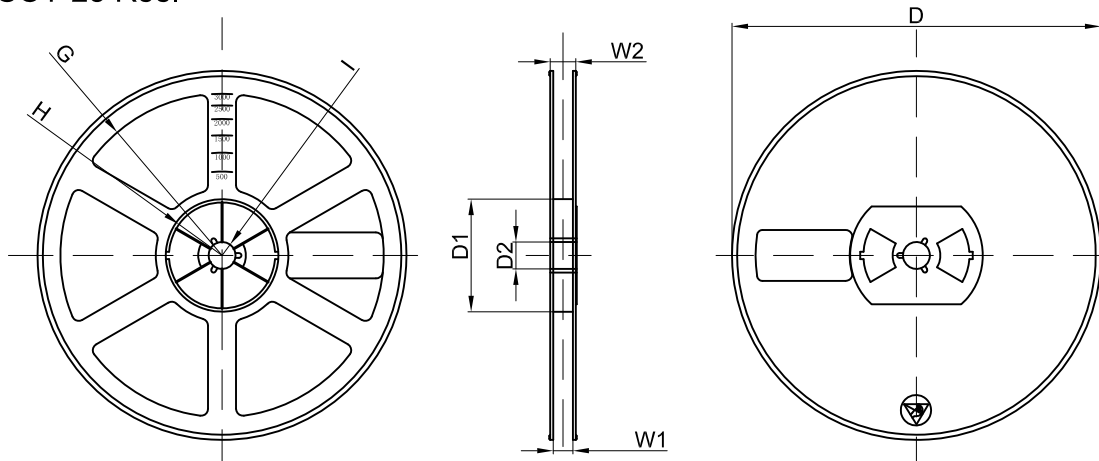

Dimensions are in millimeter								
Reel Option	D	D1	D2	G	H	I	W1	W2
7"Dia	Ø178.00	54.40	13.00	R78.00	R25.60	R6.50	9.50	12.30

REEL	Reel Size	Box	Box Size(mm)	Carton	Carton Size(mm)	G.W.(kg)
3000 pcs	7 inch	45,000 pcs	203×203×195	180,000 pcs	438×438×220	