

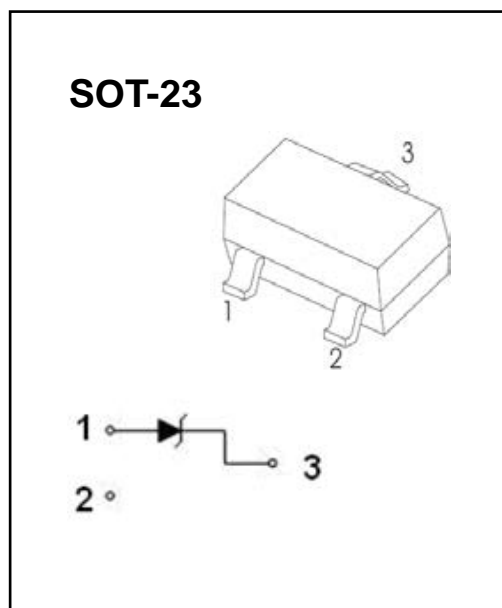

## FEATURES

- Planar Die Construction
- 300mW Power Dissipation
- Zener Voltages from 2.4V - 39V
- Ultra-Small Surface Mount Package Power Dissipation



## MAXMUM RATINGS( $T_a=25^{\circ}\text{C}$ unless otherwise specified )

Characteristic	Symbol	Value	Unit
Forward Voltage (Note 2) @ $I_F = 10\text{mA}$	$V_F$	0.9	V
Power Dissipation(Note 1)	$P_d$	300	mW
Thermal Resistance from Junction to Ambient	$R_{\theta JA}$	417	$^{\circ}\text{C} / \text{W}$
Operation Junction and Storage Temperature Range	$T_J, T_{stg}$	-55~+150	$^{\circ}\text{C}$



## ELECTRICAL CHARACTERISTICS

Type Number	Type Code	Zener Voltage Range (Note 2)				Maximum Zener Impedance (Note 3)			Maximum Reverse Current		Typical Temperature Coefficient @I <sub>ZT</sub> =5 mA	
		V <sub>Z</sub> @I <sub>ZT</sub>			I <sub>ZT</sub>	Z <sub>ZT</sub> @I <sub>ZT</sub>	Z <sub>ZK</sub> @I <sub>ZK</sub>	I <sub>ZK</sub>	I <sub>R</sub>	V <sub>R</sub>	mV/°C	
		Nom(V)	Min(V)	Max(V)	mA	Ω	mA	μA	V	Min	Max	
BZX84B2V4	2Z11	2.4	2.35	2.45	5	100	600	1.0	50	1.0	-3.5	0
BZX84B2V7	2Z12	2.7	2.65	2.75	5	100	600	1.0	20	1.0	-3.5	0
BZX84B3V0	2Z13	3	2.94	3.06	5	95	600	1.0	10	1.0	-3.5	0
BZX84B3V3	2Z14	3.3	3.23	3.37	5	95	600	1.0	5	1.0	-3.5	0
BZX84B3V6	2Z15	3.6	3.53	3.67	5	90	600	1.0	5	1.0	-3.5	0
BZX84B3V9	2Z16	3.9	3.82	3.98	5	90	600	1.0	3	1.0	-3.5	0
BZX84B4V3	2Z17	4.3	4.21	4.39	5	90	600	1.0	3	1.0	-3.5	0
BZX84B4V7	2Z1	4.7	4.61	4.79	5	80	500	1.0	3	2.0	-3.5	0.2
BZX84B5V1	2Z2	5.1	5.00	5.20	5	60	480	1.0	2	2.0	-2.7	1.2
BZX84B5V6	2Z3	5.6	5.49	5.71	5	40	400	1.0	1	2.0	-2.0	2.5
BZX84B6V2	2Z4	6.2	6.08	6.32	5	10	150	1.0	3	4.0	0.4	3.7
BZX84B6V8	2Z5	6.8	6.66	6.94	5	15	80	1.0	2	4.0	1.2	4.5
BZX84B7V5	2Z6	7.5	7.35	7.65	5	15	80	1.0	1	5.0	2.5	5.3
BZX84B8V2	2Z7	8.2	8.04	8.36	5	15	80	1.0	0.7	5.0	3.2	6.2
BZX84B9V1	2Z8	9.1	8.92	9.28	5	15	100	1.0	0.5	6.0	3.8	7.0
BZX84B10	2Z9	10	9.80	10.20	5	20	150	1.0	0.2	7.0	4.5	8.0
BZX84B11	2Y1	11	10.78	11.22	5	20	150	1.0	0.1	8.0	5.4	9.0
BZX84B12	2Y2	12	11.76	12.24	5	25	150	1.0	0.1	8.0	6.0	10.0
BZX84B13	2Y3	13	12.74	13.26	5	30	170	1.0	0.1	8.0	7.0	11.0
BZX84B15	2Y4	15	14.70	15.30	5	30	200	1.0	0.1	10.5	9.2	13.0
BZX84B16	2Y5	16	15.68	16.32	5	40	200	1.0	0.1	11.2	10.4	14.0
BZX84B18	2Y6	18	17.64	18.36	5	45	225	1.0	0.1	12.6	12.4	16.0
BZX84B20	2Y7	20	19.60	20.40	5	55	225	1.0	0.1	14.0	14.4	18.0
BZX84B22	2Y8	22	21.56	22.44	5	55	250	1.0	0.1	15.4	16.4	20.0
BZX84B24	2Y9	24	23.52	24.48	5	70	250	1.0	0.1	16.8	18.4	22.0
BZX84B27	2Y10	27	26.46	27.54	2	80	300	0.5	0.1	18.9	21.4	25.3
BZX84B30	2Y11	30	29.40	30.60	2	80	300	0.5	0.1	21.0	24.4	29.4
BZX84B33	2Y12	33	32.34	33.66	2	80	325	0.5	0.1	23.1	27.4	33.4
BZX84B36	2Y13	36	35.28	36.72	2	90	350	0.5	0.1	25.2	30.4	37.4
BZX84B39	2Y14	39	38.22	39.78	2	130	350	0.5	0.1	27.3	33.4	41.2

**Notes:**

1. Valid provided that device terminals are kept at ambient temperature.
2. Tested with pulses, period=5ms,pulse width =300μs.
3. f=1kHz.



**Typical Characteristics**

Notes: Our company currently provide 5.1 V - 20 V products only

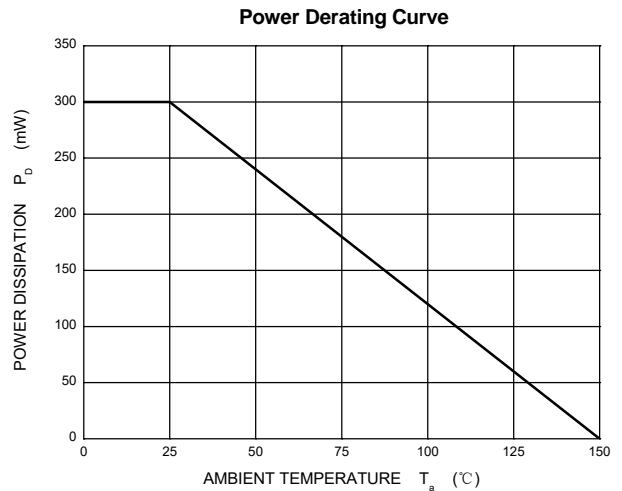
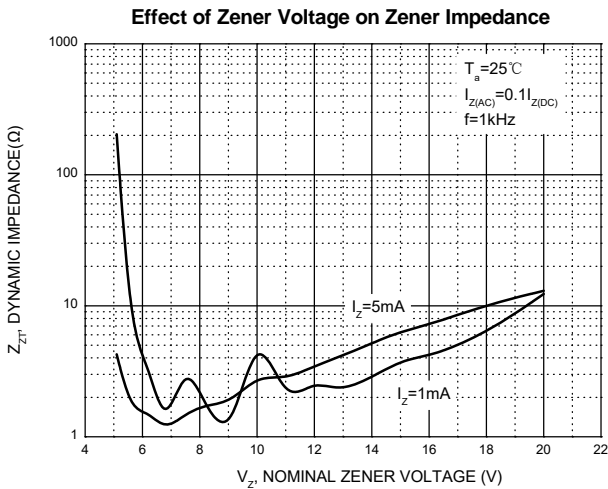
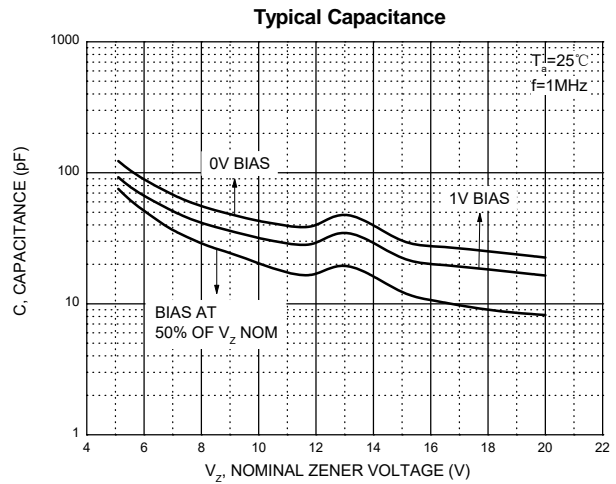
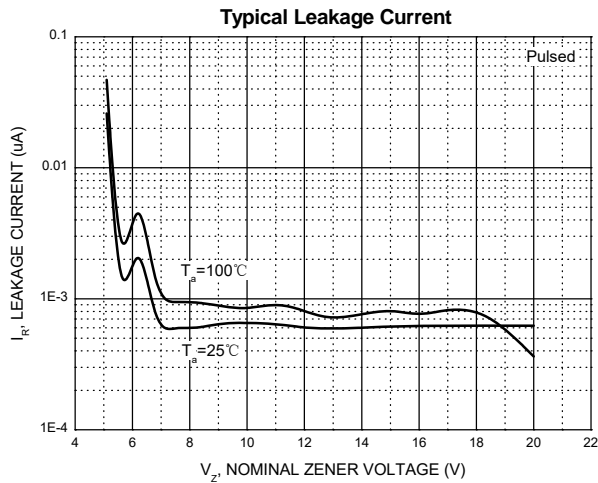
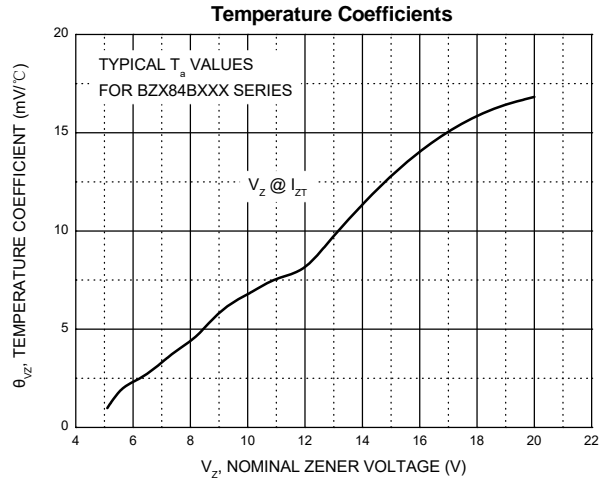
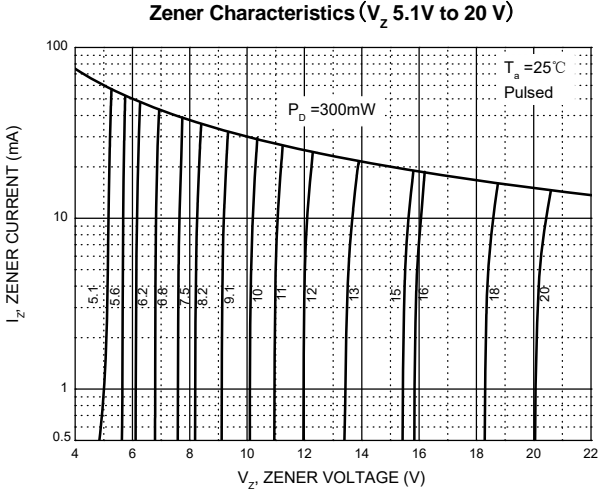

**SOT-23 Package Outline Dimensions**

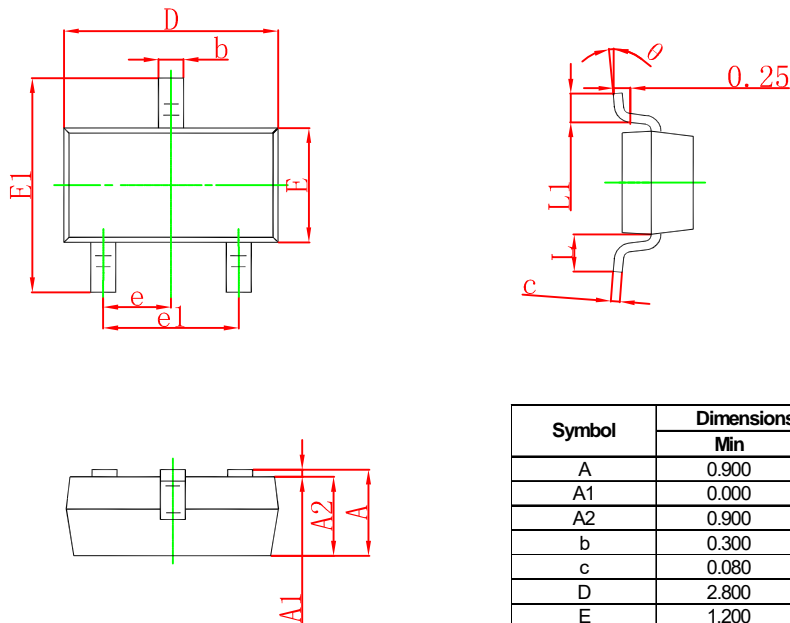

Symbol	Dimensions In Millimeters		Dimensions In Inches	
	Min	Max	Min	Max
A	0.900	1.150	0.035	0.045
A1	0.000	0.100	0.000	0.004
A2	0.900	1.050	0.035	0.041
b	0.300	0.500	0.012	0.020
c	0.080	0.150	0.003	0.006
D	2.800	3.000	0.110	0.118
E	1.200	1.400	0.047	0.055
E1	2.250	2.550	0.089	0.100
e	0.950 TYP		0.037 TYP	
e1	1.800	2.000	0.071	0.079
L	0.550 REF		0.022 REF	
L1	0.300	0.500	0.012	0.020
θ	0°	8°	0°	8°

**SOT-23 Suggested Pad Layout**

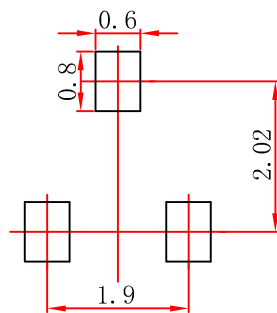

Note:  
 1. Controlling dimension: in millimeters.  
 2. General tolerance: ± 0.05mm.  
 3. The pad layout is for reference purposes only.

**SOT-23 Tape and Reel**

**SOT-23 Embossed Carrier Tape**

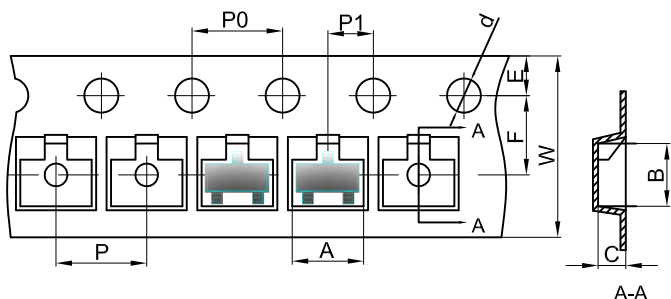

**Packaging Description:**  
SOT-23 parts are shipped in tape. The carrier tape is made from a dissipative (carbon filled) polycarbonate resin. The cover tape is a multilayer film (Heat Activated Adhesive in nature) primarily composed of polyester film, adhesive layer, sealant, and anti-static sprayed agent. These reeled parts in standard option are shipped with 3,000 units per 7" or 17.8cm diameter reel. The reels are clear in color and is made of polystyrene plastic (anti-static coated).

Dimensions are in millimeter											
Pkg type	A	B	C	d	E	F	P0	P	P1	W	
SOT-23	3.15	2.77	1.22	Ø1.50	1.75	3.50	4.00	4.00	2.00	8.00	

**SOT-23 Tape Leader and Trailer**

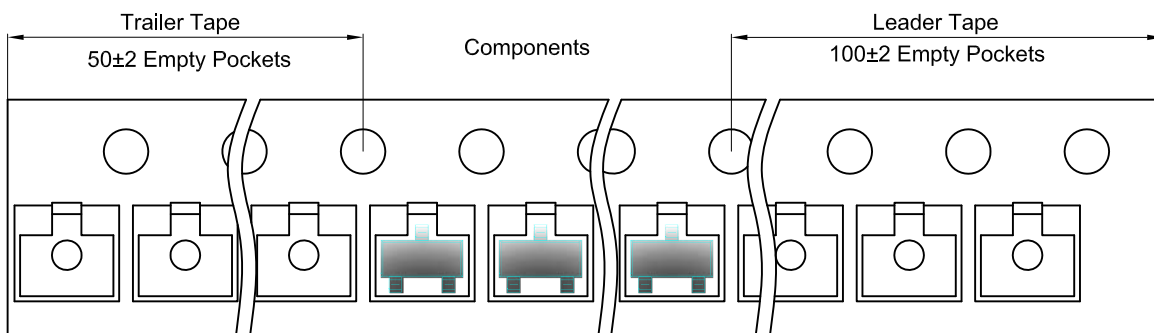

**SOT-23 Reel**

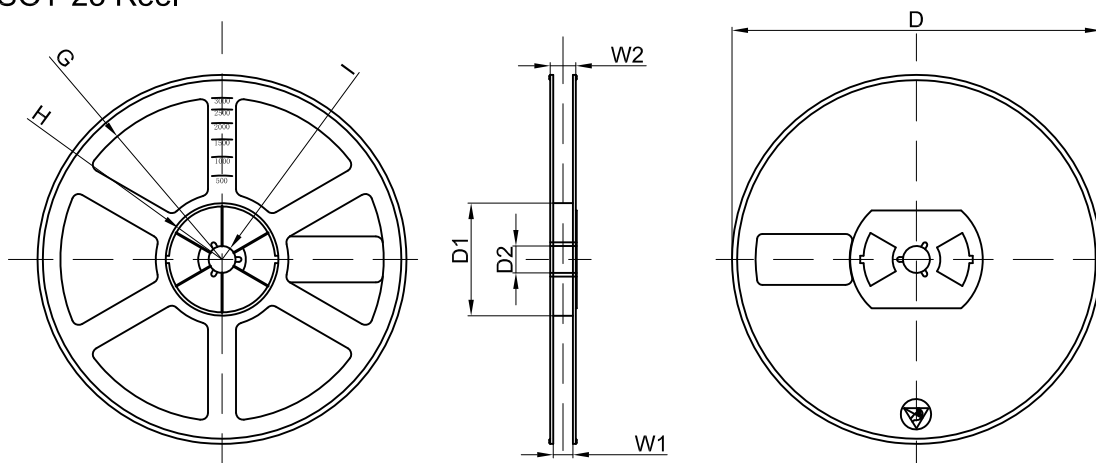

Dimensions are in millimeter								
Reel Option	D	D1	D2	G	H	I	W1	W2
7" Dia	Ø178.00	54.40	13.00	R78.00	R25.60	R6.50	9.50	12.30

REEL	Reel Size	Box	Box Size(mm)	Carton	Carton Size(mm)	G.W.(kg)
3000 pcs	7 inch	45,000 pcs	203×203×195	180,000 pcs	438×438×220	